

Atmel 8051 Microcontrollers Hardware Manual





Table of Contents

Section 1

The 8051 Instruction Set.....	1-2
1.1 Program Status Word.....	1-2
1.2 Addressing Modes	1-3
1.3 Arithmetic Instructions.....	1-5
1.4 Logical Instructions	1-6
1.5 Data Transfers	1-7
1.6 External RAM.....	1-10
1.7 Lookup Tables	1-10
1.8 Boolean Instructions	1-11
1.9 Jump Instructions.....	1-13
1.10 Read-Modify-Write Instruction Features	1-15
1.11 Instruction Set Summary.....	1-16
1.12 Instructions That Affect Flag Settings	1-20
1.13 Instruction Table	1-21
1.14 Instruction Definitions.....	1-24

Section 2

Common Features Description	2-66
2.1 Introduction	2-66
2.2 Special Function Registers	2-68
2.3 Oscillator and Clock Circuit.....	2-70
2.4 CPU Timing.....	2-71
2.5 Port Structures and Operation	2-73
2.6 Accessing External Memory.....	2-77
2.7 PSEN	2-78
2.8 ALE	2-79
2.9 Timer/Counters	2-81
2.10 Timer 0	2-82
2.11 Timer 1	2-84
2.12 Timer 2.....	2-89
2.13 Serial Interface.....	2-94
2.14 Framing Error Detection.....	2-104
2.15 Automatic Address Recognition.....	2-105
2.16 Interrupts.....	2-112



Section 1

The 8051 Instruction Set

The 8051 instruction set is optimized for 8-bit control applications. It provides a variety of fast addressing modes for accessing the internal RAM to facilitate byte operations on small data structures. The instruction set provides extensive support for one-bit variables as a separate data type, allowing direct bit manipulation in control and logic systems that require Boolean processing.

An overview of the 8051 instruction set is presented below, with a brief description of how certain instructions might be used.

1.1 Program Status Word

The Program Status Word (PSW) contains several status bits that reflect the current state of the CPU. The PSW, shown in Table 1-1 on page 3, resides in SFR space. It contains the Carry bit, the Auxiliary Carry (for BCD operations), the two register bank select bits, the Overflow flag, a parity bit, and two user-definable status flags.

The Carry bit, other than serving the functions of a Carry bit in arithmetic operations, also serves as the “Accumulator” for a number of Boolean operations.

The bits RS0 and RS1 are used to select one of the four register banks shown below.

A number of instructions refer to these RAM locations as R0 through R7. The selection of which of the four banks is being referred to is made on the basis of the bits RS0 and RS1 at execution time.

The parity bit reflects the number of 1’s in the Accumulator: $P = 1$ if the Accumulator contains an odd number of 1’s, and $P = 0$ if the Accumulator contains an even number of 1’s. Thus the number of 1’s in the Accumulator plus P is always even.

Two bits in the PSW are uncommitted and may be used as general purpose status flags.

The PSW register contains program status information as detailed in Table 1-1.

Table 1-1. PSW: Program Status Word Register

(MSB)				(LSB)			
CY	AC	F0	RS1	RS0	OV	-	P
Symbol	Position	Name and Significance					
CY	PSW.7	Carry flag					
AC	PSW.6	Auxiliary Carry flag. (For BCD operations.)					
F0	PSW.5	Flag 0 (Available to the user for general purposes.)					
RS1	PSW.4	Register bank Select control bits 1 & 0. Set/cleared by software to determine working register bank (see Note).					
RS0	PSW.3						
OV	PSW.2	Overflow flag.					
-	PSW.1	(reserved)					
P	PSW.0	Parity flag. Set/cleared by hardware each instruction cycle to indicate and odd/even number of "one" bits in the accumulator, i.e., even parity.					
Note: The contents of (RS1, RS0) enable the working register banks as follows: (0.0)-Bank 0(00H-07H) (0.1)-Bank 1(08H-0FH) (1.0)-Bank 2(10H-17H) (1.1)-Bank 3(18H-1FH)							

1.2 Addressing Modes

The addressing modes in the 8051 instruction set are as follows:

1.2.1 Direct Addressing In direct addressing the operand is specified by an 8-bit address field in the instruction. Only 128 Lowest bytes of internal Data RAM and SFRs can be directly addressed.

1.2.2 Indirect Addressing In indirect addressing the instruction specifies a register which contains the address of the operand. Both internal and external RAM can be indirectly addressed.

The address register for 8-bit addresses can be R0 or R1 of the selected register bank, or the Stack Pointer. The address register for 16-bit addresses can only be the 16-bit "data pointer" register, DPTR.

- 1.2.3 Register Instructions** The register banks, containing registers R0 through R7, can be accessed by certain instructions which carry a 3-bit register specification within the opcode of the instruction. Instructions that access the registers this way are code efficient, since this mode eliminates an address byte. When the instruction is executed, one of the eight registers in the selected bank is accessed. One of four banks is selected at execution time by the two bank select bits in the PSW.
- 1.2.4 Register-specific Instructions** Some instructions are specific to a certain register. For example, some instructions always operate on the Accumulator, or Data Pointer, etc., so no address byte is needed to point to it. The opcode does this itself. Instructions that refer to the Accumulator as 'A' assemble as accumulator-specific opcodes.
- 1.2.5 Immediate Constants** The value of a constant can follow the opcode in Program Memory. For example;
`MOV A, # 100`
loads the Accumulator with the decimal number 100. The same number could be specified in hex digits as 64H.
- 1.2.6 Indexed Addressing** Only Program Memory can be accessed with indexed addressing, and it can only be read. This addressing mode is intended for reading look-up tables in Program Memory. A 16-bit base register (either DPTR or the Program Counter) points to the base of the table, and the Accumulator is set up with the table entry number. The address of the table entry in Program Memory is formed by adding the Accumulator data to the base pointer.

Another type of indexed addressing is used in the "case jump" instruction. In this case the destination address of a jump instruction is computed as the sum of the base pointer and the Accumulator data.

1.3 Arithmetic Instructions

The menu of arithmetic instructions is listed in Table 1-2. The table indicates the addressing modes that can be used with each instruction to access the <byte> operand. For example, the ADD A, <byte> instruction can be written as:

```
ADD A, 7FH (direct addressing)
ADD A, @ R0 (indirect addressing)
ADD A, R7 (register addressing)
ADD A, # 127 (immediate constant)
```

Table 1-2. A list of the Atmel 8051 Arithmetic Instructions.

Mnemonic	Operation	Addressing Modes				Execution Time in X1 Mode @12 MHz (μs)
		Dir	Ind	Reg	Imm	
ADD A, <byte>	$A = A + \text{<byte>}$	X	X	X	X	
ADDC A, <byte>	$A = A + \text{<byte>} + C$	X	X	X	X	1
SUBB A, <byte>	$A = A - \text{<byte>} - C$	X	X	X	X	1
INC A	$A = A + 1$	Accumulator only				1
INC <byte>	$\text{<byte>} = \text{<byte>} + 1$	X	X	X		1
INC DPTR	$\text{DPTR} = \text{DPTR} + 1$	Data Pointer only				2
DEC A	$A = A - 1$	Accumulator only				1
DEC <byte>	$\text{<byte>} = \text{<byte>} - 1$	X	X	X		1
MUL AB	$B:A = B \times A$	ACC and B only				4
DIV AB	$A = \text{Int}[A/B]$ $B = \text{Mod}[A/B]$	ACC and B only				4
DA A	Decimal Adjust	Accumulator only				1

The execution times listed in Table 1-2 assume a 12 MHz clock frequency and X1 mode. All of the arithmetic instructions execute in 1 μs except the INC DPTR instruction, which takes 2 μs, and the Multiply and Divide instructions, which take 4 μs.

Note that any byte in the internal Data Memory space can be incremented or decremented without going through the Accumulator.

One of the INC instructions operates on the 16-bit Data Pointer. The Data Pointer is used to generate 16-bit addresses for external memory, so being able to increment it in one 16-bit operation is a useful feature.

The MUL AB instruction multiplies the Accumulator by the data in the B register and puts the 16-bit product into the concatenated B and Accumulator registers.

The DIV AB instruction divides the Accumulator by the data in the B register and leaves the 8-bit quotient in the Accumulator, and the 8-bit remainder in the B register.

Oddly enough, DIV AB finds less use in arithmetic “divide” routines than in radix conversions and programmable shift operations. An example of the use of DIV AB in a radix conversion will be given later. In shift operations, dividing a number by 2^n shifts its n bits to the right. Using DIV AB to perform the division completes the shift in 4 μs leaves the B register holding the bits that were shifted out.

The DA A instruction is for BCD arithmetic operations. In BCD arithmetic ADD and ADDC instructions should always be followed by a DA A operation, to ensure that the result is also in BCD. Note that DAA will not convert a binary number to BCD. The DA A operation produces a meaningful result only as the second step in the addition of two BCD bytes.

1.4 Logical Instructions

Table 1-3 shows the list of logical instructions. The instructions that perform Boolean operations (AND, OR, Exclusive OR, NOT) on bytes perform the operation on a bit-by-bit basis. That is, if the Accumulator contains 00110101B and <byte> contains 01010011B, then

```
ANL A, <byte>
```

will leave the Accumulator holding 00010001B.

The addressing modes that can be used to access the <byte> operand are listed in Table 1-3. Thus, the ANL A, <byte> instruction may take any of the following forms.

```
ANL A, 7FH(direct addressing)
ANL A, @ R1(indirect addressing)
ANL A, R6(register addressing)
ANL A, # 53H(immediate constant)
```

All of the logical instructions that are Accumulator specific execute in 1 μs (using a 12 MHz clock and X1 mode). The others take 2 μs.

Table 1-3. A list of the Atmel 8051 Logical Instructions

Mnemonic	Operation	Addressing Modes				Execution Time @ 12MHz (μs)
		Dir	Ind	Reg	Imm	
ANL A, <byte>	A = A AND <byte>	X	X	X	X	1
ANL <byte>, A	<byte> = <byte> AND A	X				1
ANL <byte>, # data	<byte> = <byte> AND # data	X				2
ORL A, <byte>	A = A OR <byte>	X	X	X	X	1
ORL <byte>, A	<byte> = <byte> OR A	X				1
ORL <byte>, # data	<byte> = <byte> OR # data	X				2
XRL A, <byte>	A = A XOR <byte>	X	X	X	X	1
XRL <byte>, A	<byte> = <byte> XOR A	X				1
XRL <byte>, # data	<byte> = <byte> XOR # data	X				2
CLR A	A = 00H	Accumulator only				1
CLP A	A = NOT A	Accumulator only				1
RL A	Rotate ACC Left 1 bit	Accumulator only				1
RLC A	Rotate Left through Carry	Accumulator only				1
RR A	Rotate ACC Right 1 bit	Accumulator only				1
RRC A	Rotate Right through Carry	Accumulator only				1
SWAP A	Swap Nibbles in A	Accumulator only				1



Note that Boolean operations can be performed on any byte in the internal Data Memory space without going through the Accumulator. The XRL <byte>, # data instruction, for example, offers a quick and easy way to invert port bits, as in

```
XRL P1, #OFFH
```

If the operation is in response to an interrupt, not using the Accumulator saves the time and effort to stack it in the service routine.

The Rotate instructions (RL A, RLC A, etc.) shift the Accumulator 1 bit to the left or right. For a left rotation, the MSB rolls into the LSB position. For a right rotation, the LSB rolls into the MSB position.

The SWAP A instruction interchanges the high and low nibbles within the Accumulator. This is a useful operation in BCD manipulations. For example, if the Accumulator contains a binary number which is known to be less than 100, it can be quickly converted to BCD by the following code:

```
MOV B, #10
DIV AB
SWAP A
ADD A, B
```

Dividing the number by 10 leaves the tens digit in the low nibble of the Accumulator, and the ones digit in the B register. The SWAP and ADD instructions move the tens digit to the high nibble of the Accumulator, and the ones digit to the low nibble.

1.5 Data Transfers

1.5.1 Internal RAM

Table 1-4 shows the menu of instructions that are available for moving data around within the internal memory spaces, and the addressing modes that can be used with each one. With a 12 MHz clock and X1 mode, all of these instructions execute in either 1 or 2 μ s.

The MOV <dest>, <src> instruction allows data to be transferred between any two internal RAM or SFR locations without going through the Accumulator. Remember the Upper 128 bytes of data RAM can be accessed only by indirect, and SFR space only by direct addressing.

Note that in all 8051 devices, the stack resides in on-chip RAM, and grows upwards. The PUSH instruction first increments the Stack Pointer (SP), then copies the byte into the stack. PUSH and POP use only direct addressing to identify the byte being saved or restored, but the stack itself is accessed by indirect addressing using the SP register.

This means the stack can go into the Upper 128, if they are implemented, but not into SFR space.

Table 1-4. Atmel 8051 Data Transfer Instructions that Access Internal Data Memory Space

Mnemonic	Operation	Addressing Modes				Execution Time @ 12MHz (µs)
		Dir	Ind	Reg	Imm	
MOV A, <src>	A = <src>	X	X	X	X	1
MOV <dest>, A	<dest> = A	X	X	X		1
MOV <dest>, <src>	<dest> = <src>	X	X	X	X	2
MOV DPTR, # data 16	DPTR = 16-bit immediate constant				X	2
PUSH <src>	INC SP: MOV “@SP”, <scr>	X				2
POP <dest>	MOV <dest>, “@SP”: DEC SP	X				2
XCH A, <byte>	ACC and <byte> Exchange Data	X	X	X		1
XCHD A, @Ri	ACC and @ Ri exchange low nibbles		X			1

The Upper 128 are not implemented in the 8 standard 8051, nor in their ROMless. With these devices, if the SP points to the Upper 128 PUSHed bytes are lost, and POPped bytes are indeterminate.

The Data Transfer instructions include a 16-bit MOV that can be used to initialize the Data Pointer (DPTR) for look-up tables in Program Memory, or for 16-bit external Data Memory accesses.

The XCH A, <byte> instruction causes the Accumulator and addressed byte to exchange data.

The XCHD A, @ Ri instruction is similar, but only the low nibbles are involved in the exchange.

To see how XCH and XCHD can be used to facilitate data manipulations, consider first the problem of shifting an 8-digit BCD number two digits to the right. Table 1-5 shows how this can be done using direct MOVs, and for comparison how it can be done using XCH instructions. To aid in understanding how the code works, the contents of the registers that are holding the BCD number and the content of the Accumulator are shown alongside each instruction to indicate their status after the instruction has been executed.

After the routine has been executed, the Accumulator contains the two digits that were shifted out on the right. Performing the routine with direct MOVs uses 14 code bytes and 9 µs of execution time (assuming a 12 MHz clock and X1 mode). The same operation with XCHs uses less code and executes almost twice as fast.

Table 1-5. Shifting a BCD Number Two Digits to the Right

	2A	2B	2C	2D	2E	ACC
MOV A,2EH	00	12	34	56	78	78
MOV 2EH, 2DH	00	12	34	56	56	78
MOV 2DH, 2CH	00	12	34	34	56	78
MOV 2CH, 2BH	00	12	12	34	56	78
MOV 2BH, # 0	00	00	12	34	56	78
Note: Using direct MOVs: 14 bytes, 9 μ s						
	2A	2B	2C	2E	2E	ACC
CLR A	00	12	34	56	78	00
XCH A,2BH	00	00	34	56	78	12
XCH A,2CH	00	00	12	56	78	34
XCH A,2DH	00	00	12	34	78	56
XCH A,2EH	00	00	12	34	56	78
Note: Using XCHs: 9 bytes, 5 μ s						

Table 1-6. Shifting a BCD Number One Digit to the Right

	2A	2B	2C	2D	2E	ACC
MOV R1,# 2EH	00	12	34	56	78	XX
MOV R0, # 2DH	00	12	34	56	78	XX
loop for R1 = 2EH:						
LOOP: MOV A, @R1	00	12	34	56	78	78
XCHD A, @R0	00	12	34	58	78	76
SWAP A	00	12	34	58	78	67
MOV @R1, A	00	12	34	58	67	67
DEC R1	00	12	34	58	67	67
DEC R0	00	12	34	58	67	67
CJNE R1, #2AH, LOOP						
loop for R1 = 2DH:	00	12	38	45	67	45
loop for R1 = 2CH:	00	18	23	45	67	23
loop for R1 = 2BH:	08	01	23	45	67	01
CLR A	08	01	23	45	67	00
XCH A,2AH	00	01	23	45	67	08

To right-shift by an odd number of digits, a one-digit shift must be executed. Table 1-6 shows a sample of code that will right-shift a BCD number one digit, using the XCHD instruction. Again, the contents of the registers holding the number and of the Accumulator are shown alongside each instruction.

First, pointers R1 and R0 are set up to point to the two bytes containing the last four BCD digits. Then a loop is executed which leaves the last byte, location 2EH, holding the last two digits of the shifted number. The pointers are decremented, and the loop is

repeated for location 2DH. The CJNE instruction (Compare and Jump if Not Equal) is a loop control that will be described later.

The loop is executed from LOOP to CJNE for R1 = 2EH, 2DH, 2CH and 2BH. At that point the digit that was originally shifted out on the right has propagated to location 2AH. Since that location should be left with 0s, the lost digit is moved to the Accumulator.

1.6 External RAM

Table 1-7 shows a list of the Data Transfer instructions that access external Data Memory. Only indirect addressing can be used. The choice is whether to use a one-byte address, @Ri, where Ri can be either R0 or R1 of the selected register bank, or a two-byte address, @DPTR. The disadvantage to using 16-bit addresses if only a few Kbytes of external RAM are involved is that 16-bit addresses use all 8 bits of Port 2 as address bus. On the other hand, 8-bit addresses allow one to address a few Kbytes of RAM, as shown in Table 1-7, without having to sacrifice all of Port 2.

All of these instructions execute in 2 μs, with a 12 MHz clock (and X1 mode).

Note that in all external Data RAM accesses, the Accumulator is always either the destination or source of the data.

The read and write strobes to external RAM are activated only during the execution of a MOVX instruction. Separately these signals are inactive, and in fact if they're not going to be used at all, their pins are available as extra I/O lines.

Table 1-7. Data Transfer Instructions that Access External Data Memory Space

Address Width	Mnemonic	Operation	Execution Time @ 12MHz (μs)
8 bits	MOVX A, @Ri	Read external RAM @ Ri	2
8 bits	MOVX @ Ri, A	Write external RAM @ Ri	2
16 bits	MOVX A, @ DPTR	Read external RAM @ DPTR	2
16 bits	MOVX @ DPTR, A	Write external RAM @ DPTR	2

1.7 Lookup Tables

Table 1-8 shows the two instructions that are available for reading lookup tables in Program Memory. Since these instructions access only Program Memory, the lookup tables can be read, not updated. The mnemonic is MOVC for “move constant”.

If the table access is to external Program Memory, then the read strobe is $\overline{\text{PSEN}}$.

The first MOVC instruction in Table 1-8 can accommodate a table of up to 256 entries, numbered 0 through 255. The number of the desired entry is loaded into the Accumulator, and the Data Pointer is set up to point to beginning of the table. Then

```
MOVC A, @A + DPTR
```

copies the desired table entry into the Accumulator.

The other MOVC instruction works the same way, except the Program Counter (PC) is used as the table base, and the table is accessed through a subroutine. First the number of the desired entry is loaded into the Accumulator, and the subroutine is called:

```
MOV A, ENTRY_NUMBER
CALLTABLE
```

The subroutine "TABLE" would look like this:

```
TABLE:MOVC A, @A + PC
RET
```

The table itself immediately follows the RET (return) instruction in Program Memory. This type of table can have up to 255 entries, numbered 1 through 255. Number 0 cannot be used, because at the time the MOVC instruction is executed, the PC contains the address of the RET instruction. An entry numbered 0 would be the RET opcode itself.

Table 1-8. Lookup Table Read Instructions

Mnemonic	Operation	Execution Time @ 12MHz (μs)
MOVC A, @A + DPTR	Read Pgm Memory at (A + DPTR)	2
MOVC A, @A + PC	Read Pgm Memory at (A + PC)	2

1.8 Boolean Instructions

8051 devices contain a complete Boolean (single-bit) processor. The internal RAM contains 128 addressable bits, and the SFR space can support up to 128 other addressable bits. All of the port lines are bit-addressable, and each one can be treated as a separate single-bit port. The instructions that access these bits are not just conditional branches, but a complete menu of move, set, clear, complement, OR and AND instructions. These kinds of bit operations are not easily obtained in other architectures with any amount of byte-oriented software.

The instruction set for the Boolean processor is shown in Table 1-9. All bit accesses are by direct addressing. Bit addresses 00H through 7FH are in the Lower 128, and bit addresses 80H through FFH are in SFR space.

Table 1-9. 8051 Boolean Instructions

Mnemonic	Operation	Execution Time @ 12MHz (μs)
ANL C,bit	C = C AND bit	2
ANL C,/bit	C = C AND (NOT bit)	2
ORL C,bit	C = C OR bit	2
ORL C,/bit	C = C OR (NOT bit)	2
MOV C,bit	C = bit	1
MOV bit,C	bit = C	2
CLR C	C = 0	1
CLR bit	bit = 0	1
SETB C	C = 1	1
SETB bit	bit = 1	1
CPL C	C = NOT C	1
CPL bit	bit = NOT bit	1
JC rel	Jump if C = 1	2
JNC rel	Jump if C = 0	2
JB bit,rel	Jump if bit = 1	2
JNB bit,rel	Jump if bit = 0	2
JBC bit,rel	Jump if bit = 1 ; CLR bit	2

Note how easily an internal flag can be moved to a port pin:

```
MOV C, FLAG
MOV P1.0, C
```

In this example, FLAG is the name of any addressable bit in the lower 128 or SFR space. An I/O line (the LSB of Port 1, in the case) is set or cleared depending on whether the flag bit is 1 or 0.

The Carry bit in the PSW is used as the single-bit Accumulator of the Boolean processor. Bit instructions that refer to the Carry bit as C assemble as Carry-specific instructions (CLR C, etc.). The Carry bit also has a direct address, since it resides in the PSW register, which is bit-addressable.

Note that the Boolean instruction set includes ANL and ORL operations, but not the XRL (Exclusive OR) operation. An XRL operation is simple to implement in software. Suppose, for example, it is required to form the Exclusive OR of two bits:

```
C= bit1 XRL bit2
```

The software to do that could be as follows:

```
MOV C, bit1
JNB bit2, OVER
CPL C
OVER: (continue)
```

First, bit 1 is moved to the Carry. If bit 2 = 0, then C now contains the correct result. That is, bit 1 XRL bit2 = bit1 if bit2 = 0. On the other hand, if bit2 = 1 C now contains the complement of the correct result. It need only be inverted (CPL C) to complete the operation.

This code uses the JNB instruction, one of a series of bit-test instructions which execute a jump if the addressed bit is set (JC, JB, JBC) or if the addressed bit is not set (JNC, JNB). In the above case, bit2 is being tested, and if bit2 = 0 the CPL C instruction is jumped over.

JBC executes the jump if the addressed bit is set, and also clears the bit. Thus a flag can be tested and cleared in one operation.

All the PSW bits are directly addressable, so the Parity bit, or the general purpose flags, for example, are also available to the bit-test instructions.

1.8.1 Relative Offset

The destination address for these jumps is specified to the assembler by a label or by an actual address in Program Memory. However, the destination address assembles to a relative offset byte. This is a signed (two's complement) offset byte which is added to the PC in two's complement arithmetic if the jump is executed.

The range of the jump is therefore -128 to +127 Program Memory bytes relative to the first byte following the instruction.

Table 1-10. Addressing Modes

R_n	Register R7-R0 of the currently selected Register Bank.
direct	8-bit internal data location's address. This could be an Internal Data RAM location (0-127) or a SFR [i.e., I/O port, control register, status register, etc. (128-255)].
@R_i	8-bit internal data RAM location (0-255) addressed indirectly through register R1 or R0.
#data	8-bit constant included in instruction.
#data 16	16-bit constant included in instruction.
addr 16	16-bit destination address. Used by LCALL and LJMP. A branch can be anywhere within the 64K byte Program Memory address space.



Table 1-10. Addressing Modes

addr 11	11-bit destination address. Used by ACALL and AJMP. The branch will be within the same 2K byte page of program memory as the first byte of the following instruction.
rel	Signed (two's complement) 8-bit offset byte. Used by SJMP and all conditional jumps. Range is -128 to +127 bytes relative to first byte of the following instruction.
bit	Direct Addressed bit in Internal Data RAM or Special Function Register.

1.9 Jump Instructions

Table 1-11 shows the list of unconditional jumps.

Table 1-11. Unconditional Jumps in Atmel 8051

Mnemonic	Operation	Execution Time @ 12MHz (μs)
JMP addr	Jump to addr	2
JMP @A + DPTR	Jump to A + DPTR	2
CALL addr	Call subroutine at addr	2
RET	Return from subroutine	2
RETI	Return from interrupt	2
NOP	No operation	1

The table lists a single “JMP addr” instruction, but in fact there are three -SJMP, LJMP, AJMP -which differ in the format of the destination address. JMP is a generic mnemonic which can be used if the programmer does not care how the jump is encoded.

The SJMP instruction encodes the destination address as relative offset, as described above. The instruction is 2 bytes long, consisting of the opcode and the relative offset byte. The jump distance is limited to range of -128 to + 127 bytes relative to the instruction following the SJMP.

The LJMP instruction encodes the destination address as a 16-bit constant. The instruction is 3 bytes long, consisting of the opcode and two address bytes. The destination address can be anywhere in the 64K Program Memory space.

The AJMP instruction encodes the destination address as an 11-bit constant. The instruction is 2 bytes long, consisting of the opcode, which itself contains 3 of the 11 address bits, followed by another byte containing the low 8 bits of the destination address. When the instruction is executed, these 11 bits are simply substituted for the low 11 bits in the PC. The high 5 bits stay the same. Hence the destination has to be within the same 2K block as the instruction following the AJMP.

In all cases the programmer specifies the destination address to the assembler in the same way: as a label or as a 16-bit constant. The assembler will put the destination address into the correct format for the given instruction. If the format required by the instruction will not support the distance to the specified destination address, a “Destination out of range” message is written, into the list file.

The JMP @ A + DPTR instruction supports case jumps. The destination address is computed at execution time as the sum of the 16-bit DPTR register and the Accumulator. Typically, DPTR is set up with the address of a jump table, and the Accumulator is given an index to the table. In a 5-way branch, for example, an integer 0 through 4 is loaded into the Accumulator.

The code to be executed might be as follows:

```
MOV DPTR, # JUMP_TABLE
MOV A, INDEX_NUMBER
RL A
JMP @ A + DPTR
```

The RLA instruction converts the index number (0 through 4) to an even number on the range 0 through 8, because each entry in the jump table is 2 bytes long:

```
JUMP_TABLE:
    AJMP CASE_0
    AJMP CASE_1
    AJMP CASE_2
    AJMP CASE_3
    AJMP CASE_4
```

Table 1-11 shows a single “CALL addr” instruction, but there are two of them -LCALL and ACALL -which differ in the format in which the subroutine address is given to the CPU. CALL is a generic mnemonic which can be used if the programmer does not care which way the address is encoded.

The LCALL instruction uses the 16-bit address format, and the subroutine can be anywhere in the 64K Program Memory space. The ACALL instruction uses the 11-bit format, and the subroutine must be in the same 2K block as the instruction following the ACALL.

In any case the programmer specifies the subroutine address to the assembler in the same way: as a label or as a 16-bit constant. The assembler will put the address into the correct format for the given instructions.

Subroutines should end a RET instruction, which returns execution following the CALL. RETI is used to return from an interrupt service routine. The only difference between RET and RETI is that RETI tells the interrupt control system that the interrupt in progress is done. If there is no interrupt in progress at the time RETI is executed, then the RETI is functionally identical to RET.

Table 1-12 shows the list of conditional jumps available to the Atmel 8051 user. All of these jumps specify the destination address by the relative offset method, and so are limited to a jump distance of -128 to + 127 bytes from the instruction following the conditional jump instruction. Important to note, however, the user specifies to the assembler the actual destination address the same way as the other jumps: as a label or a 16-bit constant.

Table 1-12. Conditional Jumps in Atmel 8051 Devices

Mnemonic	Operation	Addressing Modes				Execution Time @ 12MHz (µs)
		DIR	IND	REG	IMM	
JZ rel	Jump if A = 0	Accumulator only				2
JNZ rel	Jump if A ≠ 0	Accumulator only				2
DJNZ <byte>,rel	Decrement and jump if not zero	X		X		2
CJNZ A,<byte>,rel	Jump if A = <byte>	X			X	2
CJNE <byte>,#data,rel	Jump if <byte> = #data		X	X		2

There is no Zero bit in the PSW. The JZ and JNZ instructions test the Accumulator data for that condition.

The DJNZ instruction (Decrement and Jump if Not Zero) is for loop control. To execute a loop N times, load a counter byte with N and terminate the loop with DJNZ to the beginning of the loop, as shown below for N = 10:

```
MOV    COUNTER, # 10
LOOP: (begin loop)
    *
    *
```



```
*  
(end loop)  
DJNZ COUNTER, LOOP  
(continue)
```

The CJNE instruction (Compare and Jump if Not Equal) can also be used for loop control as in Table 1-12. Two bytes are specified in the operand field of the instruction. The jump is executed only if the two bytes are not equal. In the example of Figure 12, the two bytes were the data in R1 and the constant 2AH. The initial data in R1 was 2EH. Every time the loop was executed, R1 was decremented, and the looping was to continue until the R1 data reached 2AH.

Another application of this instruction is in “greater than, less than” comparisons. The two bytes in the operand field are taken as unsigned integers. If the first is less than the second, then the Carry bit is set (1). If the first is greater than or equal to the second, then the Carry bit is cleared.

-
- 1.10** **Read-Modify-Write Instruction Features** See Section 2.5.4, page 76.

1.11 Instruction Set Summary

Mnemonic		Description	Byte	Oscillator Period
ARITHMETIC OPERATIONS				
ADD	A,R _n	Add register to Accumulator	1	12
ADD	A,direct	Add direct byte to Accumulator	2	12
ADD	A,@R _i	Add indirect RAM to Accumulator	1	12
ADD	A,#data	Add immediate data to Accumulator	2	12
ADDC	A,R _n	Add register to Accumulator with Carry	1	12
ADDC	A,direct	Add direct byte to Accumulator with Carry	2	12
ADDC	A,@R _i	Add indirect RAM to Accumulator with Carry	1	12
ADDC	A,#data	Add immediate data to Acc with Carry	2	12
SUBB	A,R _n	Subtract Register from Acc with borrow	1	12
SUBB	A,direct	Subtract direct byte from Acc with borrow	2	12
SUBB	A,@R _i	Subtract indirect RAM from ACC with borrow	1	12
SUBB	A,#data	Subtract immediate data from Acc with borrow	2	12
INC	A	Increment Accumulator	1	12
INC	R _n	Increment register	1	12
INC	direct	Increment direct byte	2	12
INC	@R _i	Increment direct RAM	1	12
DEC	A	Decrement Accumulator	1	12
DEC	R _n	Decrement Register	1	12
DEC	direct	Decrement direct byte	2	12
DEC	@R _i	Decrement indirect RAM	1	12
INC	DPTR	Increment Data Pointer	1	24
MUL	AB	Multiply A & B	1	48
DIV	AB	Divide A by B	1	48
DA	A	Decimal Adjust Accumulator	1	12

Note: 1. All mnemonics copyrighted © Intel Corp., 1980.

Mnemonic		Description	Byte	Oscillator Period
LOGICAL OPERATIONS				
ANL	A,R _n	AND Register to Accumulator	1	12
ANL	A,direct	AND direct byte to Accumulator	2	12
ANL	A,@R _i	AND indirect RAM to Accumulator	1	12

Mnemonic		Description	Byte	Oscillator Period
ANL	A,#data	AND immediate data to Accumulator	2	12
ANL	direct,A	AND Accumulator to direct byte	2	12
ANL	direct,#data	AND immediate data to direct byte	3	24
ORL	A,R _n	OR register to Accumulator	1	12
ORL	A,direct	OR direct byte to Accumulator	2	12
ORL	A,@R _i	OR indirect RAM to Accumulator	1	12
ORL	A,#data	OR immediate data to Accumulator	2	12
ORL	direct,A	OR Accumulator to direct byte	2	12
ORL	direct,#data	OR immediate data to direct byte	3	24
XRL	A,R _n	Exclusive-OR register to Accumulator	1	12
XRL	A,direct	Exclusive-OR direct byte to Accumulator	2	12
XRL	A,@R _i	Exclusive-OR indirect RAM to Accumulator	1	12
XRL	A,#data	Exclusive-OR immediate data to Accumulator	2	12
XRL	direct,A	Exclusive-OR Accumulator to direct byte	2	12
XRL	direct,#data	Exclusive-OR immediate data to direct byte	3	24
CLR	A	Clear Accumulator	1	12
CPL	A	Complement Accumulator	1	12
RL	A	Rotate Accumulator Left	1	12
RLC	A	Rotate Accumulator Left through the Carry	1	12
LOGICAL OPERATIONS (continued)				
RR	A	Rotate Accumulator Right	1	12
RRC	A	Rotate Accumulator Right through the Carry	1	12
SWAP	A	Swap nibbles within the Accumulator	1	12
DATA TRANSFER				
MOV	A,R _n	Move register to Accumulator	1	12
MOV	A,direct	Move direct byte to Accumulator	2	12
MOV	A,@R _i	Move indirect RAM to Accumulator	1	12
MOV	A,#data	Move immediate data to Accumulator	2	12
MOV	R _n ,A	Move Accumulator to register	1	12
MOV	R _n ,direct	Move direct byte to register	2	24
MOV	R _n ,#data	Move immediate data to register	2	12
MOV	direct,A	Move Accumulator to direct byte	2	12
MOV	direct,R _n	Move register to direct byte	2	24
MOV	direct,direct	Move direct byte to direct	3	24
MOV	direct,@R _i	Move indirect RAM to direct byte	2	24

Mnemonic		Description	Byte	Oscillator Period
MOV	direct,#data	Move immediate data to direct byte	3	24
MOV	@R _i ,A	Move Accumulator to indirect RAM	1	12
MOV	@R _i ,direct	Move direct byte to indirect RAM	2	24
MOV	@R _i ,#data	Move immediate data to indirect RAM	2	12
MOV	DPTR,#data16	Load Data Pointer with a 16-bit constant	3	24
MOVC	A,@A+DPTR	Move Code byte relative to DPTR to Acc	1	24
MOVC	A,@A+PC	Move Code byte relative to PC to Acc	1	24
MOVX	A,@R _i	Move External RAM (8-bit addr) to Acc	1	24
DATA TRANSFER (continued)				
MOVX	A,@DPTR	Move External RAM (16-bit addr) to Acc	1	24
MOVX	@R _i ,A	Move Acc to External RAM (8-bit addr)	1	24
MOVX	@DPTR,A	Move Acc to External RAM (16-bit addr)	1	24
PUSH	direct	Push direct byte onto stack	2	24
POP	direct	Pop direct byte from stack	2	24
XCH	A,R _n	Exchange register with Accumulator	1	12
XCH	A,direct	Exchange direct byte with Accumulator	2	12
XCH	A,@R _i	Exchange indirect RAM with Accumulator	1	12
XCHD	A,@R _i	Exchange low-order Digit indirect RAM with Acc	1	12
BOOLEAN VARIABLE MANIPULATION				
CLR	C	Clear Carry	1	12
CLR	bit	Clear direct bit	2	12
SETB	C	Set Carry	1	12
SETB	bit	Set direct bit	2	12
CPL	C	Complement Carry	1	12
CPL	bit	Complement direct bit	2	12
ANL	C,bit	AND direct bit to CARRY	2	24
ANL	C,/bit	AND complement of direct bit to Carry	2	24
ORL	C,bit	OR direct bit to Carry	2	24
ORL	C,/bit	OR complement of direct bit to Carry	2	24
MOV	C,bit	Move direct bit to Carry	2	12
MOV	bit,C	Move Carry to direct bit	2	24
JC	rel	Jump if Carry is set	2	24
JNC	rel	Jump if Carry not set	2	24

Mnemonic		Description	Byte	Oscillator Period
JB	bit,rel	Jump if direct Bit is set	3	24
JNB	bit,rel	Jump if direct Bit is Not set	3	24
JBC	bit,rel	Jump if direct Bit is set & clear bit	3	24
PROGRAM BRANCHING				
ACALL	addr11	Absolute Subroutine Call	2	24
LCALL	addr16	Long Subroutine Call	3	24
RET		Return from Subroutine	1	24
RETI		Return from interrupt	1	24
AJMP	addr11	Absolute Jump	2	24
LJMP	addr16	Long Jump	3	24
SJMP	rel	Short Jump (relative addr)	2	24
JMP	@A+DPTR	Jump indirect relative to the DPTR	1	24
JZ	rel	Jump if Accumulator is Zero	2	24
JNZ	rel	Jump if Accumulator is Not Zero	2	24
CJNE	A,direct,rel	Compare direct byte to Acc and Jump if Not Equal	3	24
CJNE	A,#data,rel	Compare immediate to Acc and Jump if Not Equal	3	24
CJNE	R _n ,#data,rel	Compare immediate to register and Jump if Not Equal	3	24
CJNE	@R _i ,#data,rel	Compare immediate to indirect and Jump if Not Equal	3	24
DJNZ	R _n ,rel	Decrement register and Jump if Not Zero	2	24
DJNZ	direct,rel	Decrement direct byte and Jump if Not Zero	3	24
NOP		No Operation	1	12

1.12 Instructions That Affect Flag Settings

Table 1-13. Instructions that affect Flag Settings

Instruction	Flag			Instruction	Flag		
	C	OV	AC		C	OV	AC
ADD	X	X	X	CLR C	O		
ADDC	X	X	X	CPL C	X		
SUBB	X	X	X	ANL C,bit	X		
MUL	O	X		ANL C,/bit	X		
DIV	O	X		ORL C,bit	X		
DA	X			ORL C,/bit	X		
RRC	X			MOV C,bit	X		
RLC	X			CJNE	X		
SETB C	1						

Note: Operations on SFR byte address 208 or bit addresses 209-215 (that is, the PSW or bits in the PSW) also affect flag settings.

-
- 1.13 Instruction Table** Table 1-14 shows the Hex value of each instruction detailing the:
- byte size
 - number of cycles
 - flags modified by the instruction

Table 1-14. 8051 Instruction Table

	x0	x1	x2	x3	x4	x5	x6	x7
0x	NOP 1-1	AJMP addr 2-2	LJMP code 3-2	RR A 1-1	INC A 1-1	INC dir 2-1	INC @R0 1-1	INC @R1 1-1
1x	JBC bit,rel 3-2	ACALL addr 2-2	LCALL code 3-2	RRC A 1-1,C	DEC A 1-1	DEC dir 2-1	DEC @R0 1-1	DEC @R1 1-1
2x	JB bit,rel 3-2	AJMP addr11 2-2	RET 1-2	RLA 1-1	ADD A,#imm 2-1,C,OV,AC	ADD A,dir 2-1,C,OV,AC	ADD A,@R0 1-1,C,OV,AC	ADD A,@R1 1-1,C,OV,AC
3x	JNB bit,rel 3-2	ACALL addr11 2-2	RETI 1-2	RLC A 1-1,C	ADDC A,#imm 2-1,C,OV,AC	ADDC A,dir 2-1,C,OV,AC	ADDC A,@R0 1-1,C,OV,AC	ADDC A,@R1 1-1,C,OV,AC
4x	JC rel 2-2	AJMP addr11 2-2	ORL dir,A 2-1	ORL dir,#imm 3-2	ORL A,#imm 2-1	ORL A,dir 2-1	ORL A,@R0 1-1	ORL A,@R1 1-1
5x	JNC rel 2-2	ACALL addr11 2-2	ANL dir,A 2-1	ANL dir,#imm 3-2	ANL A,#imm 2-1	ANL A,dir 2-1	ANL A,@R0 1-1	ANL A,@R1 1-1
6x	JZ rel 2-2	AJMP addr11 2-2	XRL dir,A 2-1	XRL dir,#imm 3-2	XRL A,#imm 2-1	XRL A,dir 2-1	XRL A,@R0 1-1	XRL A,@R1 1-1
7x	JNZ rel 2-2	ACALL addr11 2-2	ORL C,bit 2-2,C	JMP @A+DPTR 1-2	MOV A,#imm 2-1	MOV dir,#imm 3-2	MOV @R0,#imm 2-1	MOV @R1,#imm 2-1
8x	SJMP rel 2-2	AJMP addr11 2-2	ANL C,bit 2-2,C	MOVC A,@A+PC 1-2	DIV AB 1-4,C=0,OV	MOV dir,dir 3-2	MOV dir,@R0 2-2	MOV dir,@R1 2-2
9x	MOV DPTR,#imm16 3-2	ACALL addr11 2-2	MOV bit,C 2-2	MOVC A,@A+DPTR 1-2	SUBB A,#imm 2-1,C,OV,AC	SUBB A,dir 2-1,C,OV,AC	SUBB A,@R0 1-1,C,OV,AC	SUBB A,@R1 1-1,C,OV,AC
Ax	ORL C,/bit 2-2,C	AJMP addr11 2-2	MOV C,bit 2-1,C	INC DPTR 1-2	MUL AB 1-4,C=0,OV	MOV @R0,dir 2-2	MOV @R0,dir 2-2	MOV @R1,dir 2-2
Bx	ANL C,/bit 2-2,C	ACALL addr11 2-2	CPL bit 2-1	CPL C 1-1,C	CJNE A,#imm,rel 3-2,C	CJNE A,dir,rel 3-2,C	CJNE @R0,#imm,rel 3-2,C	CJNE @R1,#imm,rel 3-2,C
Cx	PUSH dir 2-2	AJMP addr11 2-2	CLR bit 2-1	CLR C 1-1,C=0	SWAP A 1-1	XCH A,dir 2-1	XCH A,@R0 1-1	XCH A,@R1 1-1
Dx	POP dir 2-2	ACALL addr11 2-2	SETB bit 2-1	SETB C 1-1,e=1	DA A 1-1,C	DJNZ dir,rel 3-2	XCHD A,@R0 1-1	XCHD A,@R1 1-1
Ex	MOVX A,@DPTR 1-2	AJMP addr11 2-2	MOVX A,@R0 1-2	MOVX A,@R1 1-2	CLR A 1-1	MOV A,dir 2-1	MOV A,@R0 1-1	MOV A,@R1 1-1
Fx	MOVX @DPTR,A 1-2	ACALL addr11 2-2	MOVX @R0,A 1-2	MOVX @R1,A 1-2	CPL A 1-1	MOV dir,A 2-1	MOVX @R0,A 1-1	MOVX @R1,A 1-1

Table 1-14. 8051 Instruction Table (Continued)

	x8	x9	xA	xB	xC	xD	xE	xF
0x	INC R0 1-1	INVC R1 1-1	INC R2 1-1	INC R3 1-1	INC R4 1-1	INC R5 1-1	INC R6 1-1	INC R7 1-1
1x	DEC R0 1-1	DEC R1 1-1	DEC R2 1-1	DEC R3 1-1	DEC R4 1-1	DEC R5 1-1	DEC R6 1-1	DEC R7 1-1
2x	ADD A,R0 1-1,C,OV,AC	ADD A,R1 1-1,C,OV,AC	ADD A,R2 1-1,C,OV,AC	ADD A,R3 1-1,C,OV,AC	ADD A,R4 1-1,C,OV,AC	ADD A,R5 1-1,C,OV,AC	ADD A,R6 1-1,C,OV,AC	ADD A,R7 1-1,C,OV,AC
3x	ADDC A,R0 1-1,C,OV,AC	ADDC A,R1 1-1,C,OV,AC	ADDC A,R2 1-1,C,OV,AC	ADDC A,R3 1-1,C,OV,AC	ADDC A,R4 1-1,C,OV,AC	ADDC A,R5 1-1,C,OV,AC	ADDC A,R6 1-1,C,OV,AC	ADDC A,R7 1-1,C,OV,AC
4x	ORL A,R0 1-1	ORL A,R1 1-1	ORL A,R2 1-1	ORL A,R3 1-1	ORL A,R4 1-1	ORL A,R5 1-1	ORL A,R6 1-1	ORL A,R7 1-1
5x	ANL A,R0 1-1	ANL A,R1 1-1	ANL A,R2 1-1	ANL A,R3 1-1	ANL A,R4 1-1	ANL A,R5 1-1	ANL A,R6 1-1	ANL A,R7 1-1
6x	XRL A,R0 1-1	XRL A,R1 1-1	XRL A,R2 1-1	XRL A,R3 1-1	XRL A,R4 1-1	XRL A,R5 1-1	XRL A,R6 1-1	XRL A,R7 1-1
7x	MOV R0,#imm 2-1	MOV R1,#imm 2-1	MOV R2,#imm 2-1	MOV R3,#imm 2-1	MOV R4,#imm 2-1	MOV R5,#imm 2-1	MOV R6,#imm 2-1	MOV R7,#imm 2-1
8x	MOV dir,R0 2-2	MOV dir,R1 2-2	MOV dir,R2 2-2	MOV dir,R3 2-2	MOV dir,R4 2-2	MOV dir,R5 2-2	MOV dir,R6 2-2	MOV dir,R7 2-2
9x	SUBB A,R0 1-1,C,OV,AC	SUBB A,R1 1-1,C,OV,AC	SUBB A,R2 1-1,C,OV,AC	SUBB A,R3 1-1,C,OV,AC	SUBB A,R4 1-1,C,OV,AC	SUBB A,R5 1-1,C,OV,AC	SUBB A,R6 1-1,C,OV,AC	SUBB A,R7 1-1,C,OV,AC
Ax	MOV R0,dir 2-2	MOV R1,dir 2-2	MOV R2,dir 2-2	MOV R3,dir 2-2	MOV R4,dir 2-2	MOV R5,dir 2-2	MOV R6,dir 2-2	MOV R7,dir 2-2
Bx	CJNE R0,#imm,rel 3-2,C	CJNE R1,#imm,rel 3-2,C	CJNE R2,#imm,rel 3-2,C	CJNE R3,#imm,rel 3-2,C	CJNE R4,#imm,rel 3-2,C	CJNE R5,#imm,rel 3-2,C	CJNE R6,#imm,rel 3-2,C	CJNE R7,#imm,rel 3-2,C
Cx	XCH A,R0 1-1	XCH A,R1 1-1	XCH A,R2 1-1	XCH A,R3 1-1	XCH A,R4 1-1	XCH A,R5 1-1	XCH A,R6 1-1	XCH A,R7 1-1
Dx	DJNZ R0,rel 2-2	DJNZ R1,rel 2-2	DJNZ R2,rel 2-2	DJNZ R3,rel 2-2	DJNZ R4,rel 2-2	DJNZ R5,rel 2-2	DJNZ R6,rel 2-2	DJNZ R7,rel 2-2
Ex	MOV A,R0 1-1	MOV A,R1 1-1	MOV A,R2 1-1	MOV A,R3 1-1	MOV A,R4 1-1	MOV A,R5 1-1	MOV A,R6 1-1	MOV A,R7 1-1
Fx	MOVX R0,A 1-1	MOVX R1,A 1-1	MOVX R2,A 1-1	MOVX R3,A 1-1	MOVX R4,A 1-1	MOVX R5,A 1-1	MOVX R6,A 1-1	MOVX R7,A 1-1



1.14 Instruction Definitions

1.14.1 ACALL addr11

Function: Absolute Call

Description: ACALL unconditionally calls a subroutine located at the indicated address. The instruction increments the PC twice to obtain the address of the following instruction, then pushes the 16-bit result onto the stack (low-order byte first) and increments the Stack Pointer twice. The destination address is obtained by successively concatenating the five high-order bits of the incremented PC, opcode bits 7 through 5, and the second byte of the instruction. The subroutine called must therefore start within the same 2 K block of the program memory as the first byte of the instruction following ACALL. No flags are affected.

Example: Initially SP equals 07H. The label SUBRTN is at program memory location 0345 H. After executing the following instruction,

```
ACALL    SUBRTN
```

at location 0123H, SP contains 09H, internal RAM locations 08H and 09H will contain 25H and 01H, respectively, and the PC contains 0345H.

Bytes: 2

Cycles: 2

Encoding:

a10	a9	a8	1	0	0	0	1
-----	----	----	---	---	---	---	---

a7	a6	a5	a4	a3	a2	a1	a0
----	----	----	----	----	----	----	----

Operation: ACALL

$(PC) \leftarrow (PC) + 2$

$(SP) \leftarrow (SP) + 1$

$((SP)) \leftarrow (PC_{7-0})$

$(SP) \leftarrow (SP) + 1$

$((SP)) \leftarrow (PC_{15-8})$

$(PC_{10-0}) \leftarrow \text{page address}$

1.14.2 ADD A,<src-byte>

Function: Add**Description:** ADD adds the byte variable indicated to the Accumulator, leaving the result in the Accumulator. The carry and auxiliary-carry flags are set, respectively, if there is a carry-out from bit 7 or bit 3, and cleared otherwise. When adding unsigned integers, the carry flag indicates an overflow occurred.

OV is set if there is a carry-out of bit 6 but not out of bit 7, or a carry-out of bit 7 but not bit 6; otherwise, OV is cleared. When adding signed integers, OV indicates a negative number produced as the sum of two positive operands, or a positive sum from two negative operands.

Four source operand addressing modes are allowed: register, direct, register-indirect, or immediate.

Example: The Accumulator holds 0C3H (1100001B), and register 0 holds 0AAH (10101010B). The following instruction,

ADD A,R0

leaves 6DH (01101101B) in the Accumulator with the AC flag cleared and both the carry flag and OV set to 1.

ADD A,R_n**Bytes:** 1**Cycles:** 1**Encoding:**

0	0	1	0	1	r	r	r
---	---	---	---	---	---	---	---

Operation: ADD $(A) \leftarrow (A) + (R_n)$ **ADD A,direct****Bytes:** 2**Cycles:** 1**Encoding:**

0	0	1	0	0	1	0	1
---	---	---	---	---	---	---	---

direct address

Operation: ADD $(A) \leftarrow (A) + (\text{direct})$ **ADD A,@R_i****Bytes:** 1**Cycles:** 1**Encoding:**

0	0	1	0	0	1	1	i
---	---	---	---	---	---	---	---

Operation: ADD $(A) \leftarrow (A) + ((R_i))$ **ADD A,#data****Bytes:** 2**Cycles:** 1**Encoding:**

0	0	1	0	0	1	0	0
---	---	---	---	---	---	---	---

immediate data

Operation: ADD $(A) \leftarrow (A) + \#data$

1.14.3 ADDC A, <src-byte>

Function: Add with Carry

Description: ADDC simultaneously adds the byte variable indicated, the carry flag and the Accumulator contents, leaving the result in the Accumulator. The carry and auxiliary-carry flags are set respectively, if there is a carry-out from bit 7 or bit 3, and cleared otherwise. When adding unsigned integers, the carry flag indicates an overflow occurred.

OV is set if there is a carry-out of bit 6 but not out of bit 7, or a carry-out of bit 7 but not out of bit 6; otherwise OV is cleared. When adding signed integers, OV indicates a negative number produced as the sum of two positive operands or a positive sum from two negative operands.

Four source operand addressing modes are allowed: register, direct, register-indirect, or immediate.

Example: The Accumulator holds 0C3H (11000011B) and register 0 holds 0AAH (10101010B) with the carry flag set. The following instruction,

ADDC A,R0

leaves 6EH (01101110B) in the Accumulator with AC cleared and both the Carry flag and OV set to 1.

ADDC A,R_n

Bytes: 1

Cycles: 1

Encoding:

0	0	1	1	1	r	r	r
---	---	---	---	---	---	---	---

Operation: ADDC
 $(A) \leftarrow (A) + (C) + (R_n)$

ADDC A,direct

Bytes: 2

Cycles: 1

Encoding:

0	0	1	1	0	1	0	1
---	---	---	---	---	---	---	---

direct address

Operation: ADDC
 $(A) \leftarrow (A) + (C) + (\text{direct})$

ADDC A,@R_i

Bytes: 1

Cycles: 1

Encoding:

0	0	1	1	0	1	1	i
---	---	---	---	---	---	---	---

Operation: ADDC
 $(A) \leftarrow (A) + (C) + ((R_i))$

ADDC A,#data

Bytes: 2

Cycles: 1

Encoding:

0	0	1	1	0	1	0	0
---	---	---	---	---	---	---	---

immediate data

Operation: ADDC
 $(A) \leftarrow (A) + (C) + \#data$

1.14.4 AJMPaddr11

Function: Absolute Jump

Description: AJMP transfers program execution to the indicated address, which is formed at run-time by concatenating the high-order five bits of the PC (after incrementing the PC twice), opcode bits 7 through 5, and the second byte of the instruction. The destination must therefore be within the same 2 K block of program memory as the first byte of the instruction following AJMP.

Example: The label JMPADR is at program memory location 0123H. The following instruction,

```
AJMP      JMPADR
```

is at location 0345H and loads the PC with 0123H.

Bytes: 2

Cycles: 2

Encoding:

a10	a9	a8	0	0	0	0	1
-----	----	----	---	---	---	---	---

a7	a6	a5	a4	a3	a2	a1	a0
----	----	----	----	----	----	----	----

Operation: AJMP

$(PC) \leftarrow (PC) + 2$

$(PC_{10-0}) \leftarrow \text{page address}$

1.14.5 ANL<dest-byte>,<src-byte>

Function: Logical-AND for byte variables

Description: ANL performs the bitwise logical-AND operation between the variables indicated and stores the results in the destination variable. No flags are affected.

The two operands allow six addressing mode combinations. When the destination is the Accumulator, the source can use register, direct, register-indirect, or immediate addressing; when the destination is a direct address, the source can be the Accumulator or immediate data.

Note: When this instruction is used to modify an output port, the value used as the original port data will be read from the output data latch, *not* the input pins.

Example: If the Accumulator holds 0C3H (11000011B), and register 0 holds 55H (01010101B), then the following instruction,

ANL A,R0

leaves 41H (01000001B) in the Accumulator.

When the destination is a directly addressed byte, this instruction clears combinations of bits in any RAM location or hardware register. The mask byte determining the pattern of bits to be cleared would either be a constant contained in the instruction or a value computed in the Accumulator at run-time. The following instruction,

ANL P1,#01110011B

clears bits 7, 3, and 2 of output port 1.

ANL A,R_n

Bytes: 1

Cycles: 1

Encoding:

0	1	0	1	1	r	r	r
---	---	---	---	---	---	---	---

Operation: ANL
 $(A) \leftarrow (A) \wedge (R_n)$

ANL A,direct

Bytes: 2

Cycles: 1

Encoding:

0	1	0	1	0	1	0	1
---	---	---	---	---	---	---	---

direct address

Operation: ANL
 $(A) \leftarrow (A) \wedge (\text{direct})$

ANL A,@R_i

Bytes: 1

Cycles: 1

Encoding:

0	1	0	1	0	1	1	i
---	---	---	---	---	---	---	---

Operation: ANL
 $(A) \leftarrow (A) \wedge ((R_i))$

ANL A,#data

Bytes: 2

Cycles: 1

Encoding:	0	1	0	1	0	1	0	0	immediate data
-----------	---	---	---	---	---	---	---	---	----------------

Operation: ANL
 $(A) \leftarrow (A) \wedge \#data$

ANL direct,A

Bytes: 2

Cycles: 1

Encoding:	0	1	0	1	0	0	1	0	direct address
-----------	---	---	---	---	---	---	---	---	----------------

Operation: ANL
 $(direct) \leftarrow (direct) \wedge (A)$

ANL direct,#data

Bytes: 3

Cycles: 2

Encoding:	0	1	0	1	0	0	1	1	direct address	immediate data
-----------	---	---	---	---	---	---	---	---	----------------	----------------

Operation: ANL
 $(direct) \leftarrow (direct) \wedge \#data$

1.14.6 ANLC,<src-bit>

Function: Logical-AND for bit variables

Description: If the Boolean value of the source bit is a logical 0, then ANL C clears the carry flag; otherwise, this instruction leaves the carry flag in its current state. A slash (/) preceding the operand in the assembly language indicates that the logical complement of the addressed bit is used as the source value, *but the source bit itself is not affected*. No other flags are affected.

Only direct addressing is allowed for the source operand.

Example: Set the carry flag if, and only if, P1.0 = 1, ACC.7 = 1, and OV = 0:

```
MOV    C,P1.0    ;LOAD CARRY WITH INPUT PIN STATE
ANL    C,ACC.7   ;AND CARRY WITH ACCUM. BIT 7
ANL    C,/OV     ;AND WITH INVERSE OF OVERFLOW FLAG
```

ANL C,bit

Bytes: 2

Cycles: 2

Encoding:	1	0	0	0	0	0	1	0	bit address
-----------	---	---	---	---	---	---	---	---	-------------

Operation: ANL
 $(C) \leftarrow (C) \wedge (bit)$

ANL C,*bit*

Bytes: 2

Cycles: 2

Encoding:

1	0	1	1	0	0	0	0
---	---	---	---	---	---	---	---

bit address

Operation: ANL
(C) ← (C) ∧ (*bit*)

1.14.7 CJNE <dest-byte>,<src-byte>,rel

Function: Compare and Jump if Not Equal.

Description: CJNE compares the magnitudes of the first two operands and branches if their values are not equal. The branch destination is computed by adding the signed relative-displacement in the last instruction byte to the PC, after incrementing the PC to the start of the next instruction. The carry flag is set if the unsigned integer value of <dest-byte> is less than the unsigned integer value of <src-byte>; otherwise, the carry is cleared. Neither operand is affected.

The first two operands allow four addressing mode combinations: the Accumulator may be compared with any directly addressed byte or immediate data, and any indirect RAM location or working register can be compared with an immediate constant.

Example: The Accumulator contains 34H. Register 7 contains 56H. The first instruction in the sequence,

```

                CJNE    R7, # 60H, NOT_EQ
;               ...           ;R7 = 60H.
NOT_EQ:        JC      REQ_LOW    ;IF R7 < 60H.
;               ...           ;R7 > 60H.
    
```

sets the carry flag and branches to the instruction at label NOT_EQ. By testing the carry flag, this instruction determines whether R7 is greater or less than 60H.

If the data being presented to Port 1 is also 34H, then the following instruction,

```
WAIT:  CJNE  A, P1, WAIT
```

clears the carry flag and continues with the next instruction in sequence, since the Accumulator does equal the data read from P1. (If some other value was being input on P1, the program loops at this point until the P1 data changes to 34H.)

CJNE A,direct,rel

Bytes: 3

Cycles: 2

Encoding:

1	0	1	1	0	1	0	1
---	---	---	---	---	---	---	---

direct address

rel. address

Operation: (PC) ← (PC) + 3
IF (A) < > (*direct*)
THEN
 (PC) ← (PC) + *relative offset*
IF (A) < (*direct*)
THEN
 (C) ← 1
ELSE
 (C) ← 0



CJNE A,#data,rel**Bytes:** 3**Cycles:** 2**Encoding:**

1	0	1	1	0	1	0	0
---	---	---	---	---	---	---	---

immediate data

rel. address

Operation: $(PC) \leftarrow (PC) + 3$
 IF $(A) < > data$
 THEN
 $(PC) \leftarrow (PC) + relative\ offset$
 IF $(A) < data$
 THEN
 $(C) \leftarrow 1$
 ELSE
 $(C) \leftarrow 0$

CJNE R_n,#data,rel**Bytes:** 3**Cycles:** 2**Encoding:**

1	0	1	1	1	r	r	r
---	---	---	---	---	---	---	---

immediate data

rel. address

Operation: $(PC) \leftarrow (PC) + 3$
 IF $(R_n) < > data$
 THEN
 $(PC) \leftarrow (PC) + relative\ offset$
 IF $(R_n) < data$
 THEN
 $(C) \leftarrow 1$
 ELSE
 $(C) \leftarrow 0$

CJNE @R_i,data,rel**Bytes:** 3**Cycles:** 2**Encoding:**

1	0	1	1	0	1	1	i
---	---	---	---	---	---	---	---

immediate data

rel. address

Operation: $(PC) \leftarrow (PC) + 3$
 IF $((R_i)) < > data$
 THEN
 $(PC) \leftarrow (PC) + relative\ offset$
 IF $((R_i)) < data$
 THEN
 $(C) \leftarrow 1$
 ELSE
 $(C) \leftarrow 0$

1.14.8 CLR A

Function: Clear Accumulator

Description: CLR A clears the Accumulator (all bits set to 0). No flags are affected

Example: The Accumulator contains 5CH (01011100B). The following instruction, CLR A leaves the Accumulator set to 00H (00000000B).

Bytes: 1

Cycles: 1

Encoding:

1	1	1	0	0	1	0	0
---	---	---	---	---	---	---	---

Operation: CLR
(A) ← 0

1.14.9 CLR bit

Function: Clear bit

Description: CLR bit clears the indicated bit (reset to 0). No other flags are affected. CLR can operate on the carry flag or any directly addressable bit.

Example: Port 1 has previously been written with 5DH (01011101B). The following instruction, CLR P1.2 leaves the port set to 59H (01011001B).

CLR C

Bytes: 1

Cycles: 1

Encoding:

1	1	0	0	0	0	1	1
---	---	---	---	---	---	---	---

Operation: CLR
(C) ← 0

CLR bit

Bytes: 2

Cycles: 1

Encoding:

1	1	0	0	0	0	1	0
---	---	---	---	---	---	---	---

bit address

Operation: CLR
(bit) ← 0

1.14.10 CPL A

Function: Complement Accumulator

Description: CPLA logically complements each bit of the Accumulator (one's complement). Bits which previously contained a 1 are changed to a 0 and vice-versa. No flags are affected.

Example: The Accumulator contains 5CH (01011100B). The following instruction,

CPL A

leaves the Accumulator set to 0A3H (10100011B).

Bytes: 1

Cycles: 1

Encoding:

1	1	1	1	0	1	0	0
---	---	---	---	---	---	---	---

Operation: CPL
(A) ← (A)

1.14.11 CPL bit

Function: Complement bit

Description: CPL bit complements the bit variable specified. A bit that had been a 1 is changed to 0 and vice-versa. No other flags are affected. CLR can operate on the carry or any directly addressable bit.

Note: When this instruction is used to modify an output pin, the value used as the original data is read from the output data latch, *not* the input pin.

Example: Port 1 has previously been written with 5BH (01011101B). The following instruction sequence, CPL P1.1CPL P1.2 leaves the port set to 5BH (01011011B).

CPL C

Bytes: 1

Cycles: 1

Encoding:

1	0	1	1	0	0	1	1
---	---	---	---	---	---	---	---

Operation: CPL
(C) ← (C)

CPL bit

Bytes: 2

Cycles: 1

Encoding:

1	0	1	1	0	0	1	0
---	---	---	---	---	---	---	---

bit address

Operation: CPL
(bit) ← (bit)

1.14.12 DA A

Function: Decimal-adjust Accumulator for Addition

Description: DA A adjusts the eight-bit value in the Accumulator resulting from the earlier addition of two variables (each in packed-BCD format), producing two four-bit digits. Any ADD or ADDC instruction may have been used to perform the addition.

If Accumulator bits 3 through 0 are greater than nine (xxxx1010-xxxx1111), or if the AC flag is one, six is added to the Accumulator producing the proper BCD digit in the low-order nibble. This internal addition sets the carry flag if a carry-out of the low-order four-bit field propagates through all high-order bits, but it does not clear the carry flag otherwise.

If the carry flag is now set, or if the four high-order bits now exceed nine (1010xxxx-1111xxxx), these high-order bits are incremented by six, producing the proper BCD digit in the high-order nibble. Again, this sets the carry flag if there is a carry-out of the high-order bits, but does not clear the carry. The carry flag thus indicates if the sum of the original two BCD variables is greater than 100, allowing multiple precision decimal addition. OV is not affected.

All of this occurs during the one instruction cycle. Essentially, this instruction performs the decimal conversion by adding 00H, 06H, 60H, or 66H to the Accumulator, depending on initial Accumulator and PSW conditions.

Note: DA A *cannot* simply convert a hexadecimal number in the Accumulator to BCD notation, nor does DAA apply to decimal subtraction.

Example: The Accumulator holds the value 56H (01010110B), representing the packed BCD digits of the decimal number 56. Register 3 contains the value 67H (01100111B), representing the packed BCD digits of the decimal number 67. The carry flag is set. The following instruction sequence

```
ADDC    A,R3
DA      A
```

first performs a standard two's-complement binary addition, resulting in the value 0BEH (10111110) in the Accumulator. The carry and auxiliary carry flags are cleared.

The Decimal Adjust instruction then alters the Accumulator to the value 24H (00100100B), indicating the packed BCD digits of the decimal number 24, the low-order two digits of the decimal sum of 56, 67, and the carry-in. The carry flag is set by the Decimal Adjust instruction, indicating that a decimal overflow occurred. The true sum of 56, 67, and 1 is 124.

BCD variables can be incremented or decremented by adding 01H or 99H. If the Accumulator initially holds 30H (representing the digits of 30 decimal), then the following instruction sequence,

```
ADD     A, # 99H
DA      A
```

leaves the carry set and 29H in the Accumulator, since $30 + 99 = 129$. The low-order byte of the sum can be interpreted to mean $30 - 1 = 29$.

Bytes: 1

Cycles: 1

Encoding:

1	1	0	1	0	1	0	0
---	---	---	---	---	---	---	---

Operation: DA
 -contents of Accumulator are BCD
 IF $[(A_{3-0}) > 9] \vee [(AC) = 1]$
 THEN $(A_{3-0}) \leftarrow (A_{3-0}) + 6$
 AND
 IF $[(A_{7-4}) > 9] \vee [(C) = 1]$
 THEN $(A_{7-4}) \leftarrow (A_{7-4}) + 6$

1.14.13 DECbyte

Function: Decrement

Description: DEC byte decrements the variable indicated by 1. An original value of 00H underflows to 0FFH. No flags are affected. Four operand addressing modes are allowed: accumulator, register, direct, or register-indirect.

Note: When this instruction is used to modify an output port, the value used as the original port data will be read from the output data latch, *not* the input pins.

Example: Register 0 contains 7FH (01111111B). Internal RAM locations 7EH and 7FH contain 00H and 40H, respectively. The following instruction sequence,

```
DEC    @R0
```

```
DEC    R0
```

```
DEC    @R0
```

leaves register 0 set to 7EH and internal RAM locations 7EH and 7FH set to 0FFH and 3FH.

DEC A

Bytes: 1

Cycles: 1

Encoding:

0	0	0	1	0	1	0	0
---	---	---	---	---	---	---	---

Operation: DEC
(A) ← (A) - 1

DEC R_n

Bytes: 1

Cycles: 1

Encoding:

0	0	0	1	1	r	r	r
---	---	---	---	---	---	---	---

Operation: DEC
(R_n) ← (R_n) - 1

DEC direct

Bytes: 2

Cycles: 1

Encoding:

0	0	0	1	0	1	0	1
---	---	---	---	---	---	---	---

direct address

Operation: DEC
(direct) ← (direct) - 1

DEC @R_i

Bytes: 1

Cycles: 1

Encoding:

0	0	0	1	0	1	1	i
---	---	---	---	---	---	---	---

Operation: DEC
((R_i)) ← ((R_i)) - 1

1.14.14 DIVAB

Function: Divide

Description: DIV AB divides the unsigned eight-bit integer in the Accumulator by the unsigned eight-bit integer in register B. The Accumulator receives the integer part of the quotient; register B receives the integer remainder. The carry and OV flags are cleared.

Exception: if B had originally contained 00H, the values returned in the Accumulator and B-register are undefined and the overflow flag are set. The carry flag is cleared in any case.

Example: The Accumulator contains 251 (0FBH or 11111011B) and B contains 18 (12H or 00010010B). The following instruction,

DIV AB

leaves 13 in the Accumulator (0DH or 00001101B) and the value 17 (11H or 00010001B) in B, since $251 = (13 \times 18) + 17$. Carry and OV are both cleared.

Bytes: 1

Cycles: 4

Encoding:

1	0	0	0	0	0	1	0	0	0
---	---	---	---	---	---	---	---	---	---

Operation: DIV
 $(A)_{15-8} \leftarrow (A)/(B)$
 $(B)_{7-0}$

1.14.15 DJNZ<byte>,<rel-addr>

Function: Decrement and Jump if Not Zero

Description: DJNZ decrements the location indicated by 1, and branches to the address indicated by the second operand if the resulting value is not zero. An original value of 00H underflows to 0FFH. No flags are affected. The branch destination is computed by adding the signed relative-displacement value in the last instruction byte to the PC, after incrementing the PC to the first byte of the following instruction.

The location decremented may be a register or directly addressed byte.

Note: When this instruction is used to modify an output port, the value used as the original port data will be read from the output data latch, *not* the input pins.

Example: Internal RAM locations 40H, 50H, and 60H contain the values 01H, 70H, and 15H, respectively. The following instruction sequence,

```
DJNZ    40H,LABEL_1
DJNZ    50H,LABEL_2
DJNZ    60H,LABEL_3
```

causes a jump to the instruction at label LABEL_2 with the values 00H, 6FH, and 15H in the three RAM locations. The first jump was *not* taken because the result was zero.

This instruction provides a simple way to execute a program loop a given number of times or for adding a moderate time delay (from 2 to 512 machine cycles) with a single instruction. The following instruction sequence,

```
MOV     R2, # 8
TOGGLE: CPL     P1.7
        DJNZ    R2,TOGGLE
```

toggles P1.7 eight times, causing four output pulses to appear at bit 7 of output Port 1. Each pulse lasts three machine cycles; two for DJNZ and one to alter the pin.

DJNZ R_n,rel

Bytes: 2

Cycles: 2

Encoding:

1	1	0	1	1	r	r	r
---	---	---	---	---	---	---	---

rel. address

Operation: DJNZ
 $(PC) \leftarrow (PC) + 2$
 $(R_n) \leftarrow (R_n) - 1$
 IF $(R_n) > 0$ or $(R_n) < 0$
 THEN
 $(PC) \leftarrow (PC) + rel$

DJNZ direct,rel

Bytes: 3

Cycles: 2

Encoding:

1	1	0	1	0	1	0	1
---	---	---	---	---	---	---	---

direct address

rel. address

Operation: DJNZ
 $(PC) \leftarrow (PC) + 2$
 $(direct) \leftarrow (direct) - 1$
 IF $(direct) > 0$ or $(direct) < 0$
 THEN
 $(PC) \leftarrow (PC) + rel$

1.14.16 INC<byte>

Function: Increment

Description: INC increments the indicated variable by 1. An original value of 0FFH overflows to 00H. No flags are affected. Three addressing modes are allowed: register, direct, or register-indirect.

Note: When this instruction is used to modify an output port, the value used as the original port data will be read from the output data latch, *not* the input pins.

Example: Register 0 contains 7EH (011111110B). Internal RAM locations 7EH and 7FH contain 0FFH and 40H, respectively. The following instruction sequence,

INC @R0

INC R0

INC @R0

leaves register 0 set to 7FH and internal RAM locations 7EH and 7FH holding 00H and 41H, respectively.

INC A

Bytes: 1

Cycles: 1

Encoding:

0	0	0	0	0	0	1	0	0
---	---	---	---	---	---	---	---	---

Operation: INC
(A) ← (A) + 1

INC R_n

Bytes: 1

Cycles: 1

Encoding:

0	0	0	0	1	r	r	r
---	---	---	---	---	---	---	---

Operation: INC
(R_n) ← (R_n) + 1

INC direct

Bytes: 2

Cycles: 1

Encoding:

0	0	0	0	0	1	0	1
---	---	---	---	---	---	---	---

direct address

Operation: INC
(direct) ← (direct) + 1

INC @R_i

Bytes: 1

Cycles: 1

Encoding:

0	0	0	0	0	0	1	1	i
---	---	---	---	---	---	---	---	---

Operation: INC
((R_i)) ← ((R_i)) + 1

1.14.17 INC DPTR

Function: Increment Data Pointer

Description: INC DPTR increments the 16-bit data pointer by 1. A 16-bit increment (modulo 2^{16}) is performed, and an overflow of the low-order byte of the data pointer (DPL) from 0FFH to 00H increments the high-order byte (DPH). No flags are affected.

This is the only 16-bit register which can be incremented.

Example: Registers DPH and DPL contain 12H and 0FEH, respectively. The following instruction sequence,

```
INC    DPTR
INC    DPTR
INC    DPTR
```

changes DPH and DPL to 13H and 01H.

Bytes: 1

Cycles: 2

Encoding:

1	0	1	0	0	0	1	1
---	---	---	---	---	---	---	---

Operation: INC
(DPTR) \leftarrow (DPTR) + 1

1.14.18 JB bit,rel

Function: Jump if Bit set

Description: If the indicated bit is a one, JB jump to the address indicated; otherwise, it proceeds with the next instruction. The branch destination is computed by adding the signed relative-displacement in the third instruction byte to the PC, after incrementing the PC to the first byte of the next instruction. The bit tested is not modified. No flags are affected.

Example: The data present at input port 1 is 11001010B. The Accumulator holds 56 (01010110B). The following instruction sequence,

```
JB    P1.2,LABEL1
JB    ACC. 2,LABEL2
```

causes program execution to branch to the instruction at label LABEL2.

Bytes: 3

Cycles: 2

Encoding:

0	0	1	0	0	0	0	0
---	---	---	---	---	---	---	---

bit address

rel. address

Operation: JB
(PC) \leftarrow (PC) + 3
IF (bit) = 1
THEN
(PC) \leftarrow (PC) + rel

1.14.19 JBC bit,rel

Function: Jump if Bit is set and Clear bit

Description: If the indicated bit is one, JBC branches to the address indicated; otherwise, it proceeds with the next instruction. *The bit will not be cleared if it is already a zero.* The branch destination is computed by adding the signed relative-displacement in the third instruction byte to the PC, after incrementing the PC to the first byte of the next instruction. No flags are affected.

Note: When this instruction is used to test an output pin, the value used as the original data will be read from the output data latch, *not* the input pin.

Example: The Accumulator holds 56H (01010110B). The following instruction sequence,

```
JBC     ACC.3,LABEL1
JBC     ACC.2,LABEL2
```

causes program execution to continue at the instruction identified by the label LABEL2, with the Accumulator modified to 52H (01010010B).

Bytes: 3

Cycles: 2

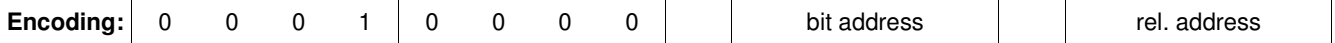

Operation: JBC
 $(PC) \leftarrow (PC) + 3$
 IF (bit) = 1
 THEN
 (bit) \leftarrow 0
 $(PC) \leftarrow (PC) + rel$

1.14.20 JC rel

Function: Jump if Carry is set

Description: If the carry flag is set, JC branches to the address indicated; otherwise, it proceeds with the next instruction. The branch destination is computed by adding the signed relative-displacement in the second instruction byte to the PC, after incrementing the PC twice. No flags are affected.

Example: The carry flag is cleared. The following instruction sequence,

```
JC     LABEL1
CPL   C
JC     LABEL 2
```

sets the carry and causes program execution to continue at the instruction identified by the label LABEL2.

Bytes: 2

Cycles: 2

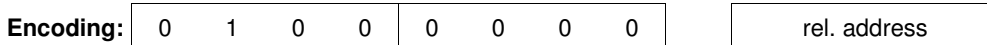

Operation: JC
 $(PC) \leftarrow (PC) + 2$
 IF (C) = 1
 THEN
 $(PC) \leftarrow (PC) + rel$



1.14.21 JMP @A+DPTR

Function: Jump indirect

Description: JMP @A+DPTR adds the eight-bit unsigned contents of the Accumulator with the 16-bit data pointer and loads the resulting sum to the program counter. This is the address for subsequent instruction fetches. Sixteen-bit addition is performed (modulo 2^{16}): a carry-out from the low-order eight bits propagates through the higher-order bits. Neither the Accumulator nor the Data Pointer is altered. No flags are affected.

Example: An even number from 0 to 6 is in the Accumulator. The following sequence of instructions branches to one of four AJMP instructions in a jump table starting at JMP_TBL.

```

MOV     DPTR, # JMP_TBL
JMP     @A + DPTR
JMP_TBL: AJMP  LABEL0
        AJMP  LABEL1
        AJMP  LABEL2
        AJMP  LABEL3

```

If the Accumulator equals 04H when starting this sequence, execution jumps to label LABEL2. Because AJMP is a 2-byte instruction, the jump instructions start at every other address.

Bytes: 1

Cycles: 2

Encoding:

0	1	1	1	0	0	1	1
---	---	---	---	---	---	---	---

Operation: JMP
(PC) \leftarrow (A) + (DPTR)

1.14.22 JNB bit,rel

Function: Jump if Bit Not set

Description: If the indicated bit is a 0, JNB branches to the indicated address; otherwise, it proceeds with the next instruction. The branch destination is computed by adding the signed relative-displacement in the third instruction byte to the PC, after incrementing the PC to the first byte of the next instruction. *The bit tested is not modified.* No flags are affected.

Example: The data present at input port 1 is 11001010B. The Accumulator holds 56H (01010110B). The following instruction sequence,

```

JNB     P1.3,LABEL1
JNB     ACC.3,LABEL2

```

causes program execution to continue at the instruction at label LABEL2.

Bytes: 3

Cycles: 2

Encoding:

0	0	1	1	0	0	0	0
---	---	---	---	---	---	---	---

bit address

 rel. address

Operation: JNB
(PC) \leftarrow (PC) + 3
IF (bit) = 0
THEN (PC) \leftarrow (PC) + rel

1.14.23 JNC rel

Function: Jump if Carry not set

Description: If the carry flag is a 0, JNC branches to the address indicated; otherwise, it proceeds with the next instruction. The branch destination is computed by adding the signal relative-displacement in the second instruction byte to the PC, after incrementing the PC twice to point to the next instruction. The carry flag is not modified.

Example: The carry flag is set. The following instruction sequence,

```
JNC     LABEL1
CPL     C
JNC     LABEL2
```

clears the carry and causes program execution to continue at the instruction identified by the label LABEL2.

Bytes: 2

Cycles: 2

Encoding:

0	1	0	1	0	0	0	0
---	---	---	---	---	---	---	---

rel. address

Operation: JNC
 $(PC) \leftarrow (PC) + 2$
 IF $(C) = 0$
 THEN $(PC) \leftarrow (PC) + rel$

1.14.24 JNZ rel

Function: Jump if Accumulator Not Zero

Description: If any bit of the Accumulator is a one, JNZ branches to the indicated address; otherwise, it proceeds with the next instruction. The branch destination is computed by adding the signed relative-displacement in the second instruction byte to the PC, after incrementing the PC twice. The Accumulator is not modified. No flags are affected.

Example: The Accumulator originally holds 00H. The following instruction sequence,

```
JNZ     LABEL1
INC     A
JNZ     LABEL2
```

sets the Accumulator to 01H and continues at label LABEL2.

Bytes: 2

Cycles: 2

Encoding:

0	1	1	1	0	0	0	0
---	---	---	---	---	---	---	---

rel. address

Operation: JNZ
 $(PC) \leftarrow (PC) + 2$
 IF $(A) \neq 0$
 THEN $(PC) \leftarrow (PC) + rel$

1.14.25 JZ rel

Function: Jump if Accumulator Zero

Description: If all bits of the Accumulator are 0, JZ branches to the address indicated; otherwise, it proceeds with the next instruction. The branch destination is computed by adding the signed relative-displacement in the second instruction byte to the PC, after incrementing the PC twice. The Accumulator is not modified. No flags are affected.

Example: The Accumulator originally contains 01H. The following instruction sequence,

```
JZ      LABEL1
DEC     A
JZ      LABEL2
```

changes the Accumulator to 00H and causes program execution to continue at the instruction identified by the label LABEL2.

Bytes: 2

Cycles: 2

Encoding:

0	1	1	0	0	0	0	0
---	---	---	---	---	---	---	---

rel. address

Operation: JZ
 $(PC) \leftarrow (PC) + 2$
 IF $(A) = 0$
 THEN $(PC) \leftarrow (PC) + rel$

1.14.26 LCALLaddr16

Function: Long call

Description: LCALL calls a subroutine located at the indicated address. The instruction adds three to the program counter to generate the address of the next instruction and then pushes the 16-bit result onto the stack (low byte first), incrementing the Stack Pointer by two. The high-order and low-order bytes of the PC are then loaded, respectively, with the second and third bytes of the LCALL instruction. Program execution continues with the instruction at this address. The subroutine may therefore begin anywhere in the full 64K byte program memory address space. No flags are affected.

Example: Initially the Stack Pointer equals 07H. The label SUBRTN is assigned to program memory location 1234H. After executing the instruction,

```
LCALL  SUBRTN
```

at location 0123H, the Stack Pointer will contain 09H, internal RAM locations 08H and 09H will contain 26H and 01H, and the PC will contain 1234H.

Bytes: 3

Cycles: 2

Encoding:

0	0	0	1	0	0	1	0
---	---	---	---	---	---	---	---

addr15-addr8

addr7-addr0

Operation: LCALL
 $(PC) \leftarrow (PC) + 3$
 $(SP) \leftarrow (SP) + 1$
 $((SP)) \leftarrow (PC_{7-0})$
 $(SP) \leftarrow (SP) + 1$
 $((SP)) \leftarrow (PC_{15-8})$
 $(PC) \leftarrow addr_{15-0}$

1.14.27 LJMPPaddr16

Function: Long Jump

Description: LJMP causes an unconditional branch to the indicated address, by loading the high-order and low-order bytes of the PC (respectively) with the second and third instruction bytes. The destination may therefore be anywhere in the full 64K program memory address space. No flags are affected.

Example: The label JMPADR is assigned to the instruction at program memory location 1234H. The instruction,
 LJMP JMPADR
 at location 0123H will load the program counter with 1234H.

Bytes: 3

Cycles: 2

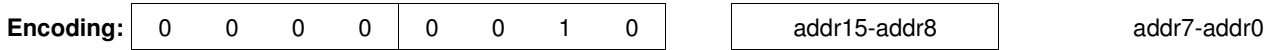

Operation: LJMP
 (PC) ← addr₁₅₋₀

1.14.28 MOV <dest-byte>,<src-byte>

Function: Move byte variable

Description: The byte variable indicated by the second operand is copied into the location specified by the first operand. The source byte is not affected. No other register or flag is affected.

This is by far the most flexible operation. Fifteen combinations of source and destination addressing modes are allowed.

Example: Internal RAM location 30H holds 40H. The value of RAM location 40H is 10H. The data present at input port 1 is 11001010B (0CAH).

```
MOV       R0,#30H     ;R0 <= 30H
MOV       A,@R0       ;A <= 40H
MOV       R1,A        ;R1 <= 40H
MOV       B,@R1       ;B <= 10H
MOV       @R1,P1      ;RAM (40H) <= 0CAH
MOV       P2,P1       ;P2 #0CAH
```

leaves the value 30H in register 0, 40H in both the Accumulator and register 1, 10H in register B, and 0CAH (11001010B) both in RAM location 40H and output on port 2.

MOV A,R_n

Bytes: 1

Cycles: 1



Operation: MOV
 (A) ← (R_n)



***MOV A,direct**

Bytes: 2

Cycles: 1

Encoding:

1	1	1	0	0	1	0	1
---	---	---	---	---	---	---	---

direct address

Operation: MOV
(A) ← (direct)*** MOV A,ACC is not a valid Instruction.****MOV A,@R_i**

Bytes: 1

Cycles: 1

Encoding:

1	1	1	0	0	1	1	i
---	---	---	---	---	---	---	---

Operation: MOV
(A) ← ((R_i))**MOV A,#data**

Bytes: 2

Cycles: 1

Encoding:

0	1	1	1	0	1	0	0
---	---	---	---	---	---	---	---

immediate data

Operation: MOV
(A) ← #data**MOV R_n,A**

Bytes: 1

Cycles: 1

Encoding:

1	1	1	1	1	r	r	r
---	---	---	---	---	---	---	---

Operation: MOV
(R_n) ← (A)**MOV R_n,direct**

Bytes: 2

Cycles: 2

Encoding:

1	0	1	0	1	r	r	r
---	---	---	---	---	---	---	---

direct addr.

Operation: MOV
(R_n) ← (direct)**MOV R_n,#data**

Bytes: 2

Cycles: 1

Encoding:

0	1	1	1	1	r	r	r
---	---	---	---	---	---	---	---

immediate data

Operation: MOV
(R_n) ← #data

MOV direct,A

Bytes: 2

Cycles: 1

Encoding:

1	1	1	1	0	1	0	1
---	---	---	---	---	---	---	---

direct address

Operation: MOV
(direct) ← (A)

MOV direct,R_n

Bytes: 2

Cycles: 2

Encoding:

1	0	0	0	1	r	r	r
---	---	---	---	---	---	---	---

direct address

Operation: MOV
(direct) ← (R_n)

MOV direct,direct

Bytes: 3

Cycles: 2

Encoding:

1	0	0	0	0	1	0	1
---	---	---	---	---	---	---	---

dir. addr. (scr) dir. addr. (dest)

Operation: MOV
(direct) ← (direct)

MOV direct,@R_i

Bytes: 2

Cycles: 2

Encoding:

1	0	0	0	0	1	1	i
---	---	---	---	---	---	---	---

direct addr.

Operation: MOV
(direct) ← ((R_i))

MOV direct,#data

Bytes: 3

Cycles: 2

Encoding:

0	1	1	1	0	1	0	1
---	---	---	---	---	---	---	---

direct address immediate data

Operation: MOV
(direct) ← #data

MOV @R_i,A

Bytes: 1

Cycles: 1

Encoding:

1	1	1	1	0	1	1	i
---	---	---	---	---	---	---	---

Operation: MOV
((R_i)) ← (A)

MOV @R_i,direct

Bytes: 2

Cycles: 2

Encoding:	1	0	1	0	0	1	1	i	direct addr.
-----------	---	---	---	---	---	---	---	---	--------------

Operation: MOV
 ((R_i)) ← (direct)

MOV @R_i,#data

Bytes: 2

Cycles: 1

Encoding:	0	1	1	1	0	1	1	i	immediate data
-----------	---	---	---	---	---	---	---	---	----------------

Operation: MOV
 ((R_i)) ← #data

1.14.29 MOV <dest-bit>,<src-bit>**Function:** Move bit data

Description: MOV <dest-bit>,<src-bit> copies the Boolean variable indicated by the second operand into the location specified by the first operand. One of the operands must be the carry flag; the other may be any directly addressable bit. No other register or flag is affected.

Example: The carry flag is originally set. The data present at input Port 3 is 11000101B. The data previously written to output Port 1 is 35H (00110101B).

MOV P1.3,C

MOV C,P3.3

MOV P1.2,C

leaves the carry cleared and changes Port 1 to 39H (00111001B).

MOV C,bit

Bytes: 2

Cycles: 1

Encoding:	1	0	1	0	0	0	1	0	bit address
-----------	---	---	---	---	---	---	---	---	-------------

Operation: MOV
 (C) ← (bit)

MOV bit,C

Bytes: 2

Cycles: 2

Encoding:	1	0	0	1	0	0	1	0	bit address
-----------	---	---	---	---	---	---	---	---	-------------

Operation: MOV
 (bit) ← (C)

1.14.30 MOV DPTR,#data16

Function: Load Data Pointer with a 16-bit constant

Description: MOV DPTR,#data16 loads the Data Pointer with the 16-bit constant indicated. The 16-bit constant is loaded into the second and third bytes of the instruction. The second byte (DPH) is the high-order byte, while the third byte (DPL) holds the lower-order byte. No flags are affected.

This is the only instruction which moves 16 bits of data at once.

Example: The instruction,

```
MOV     DPTR, # 1234H
```

loads the value 1234H into the Data Pointer: DPH holds 12H, and DPL holds 34H.

Bytes: 3

Cycles: 2

Encoding:

1	0	0	1	0	0	0	0
---	---	---	---	---	---	---	---

immed. data15-8

immed. data7-0

Operation: MOV
(DPTR) ← #data₁₅₋₀
DPH ← DPL ← #data₁₅₋₈ ← #data₇₋₀

1.14.31 MOVC A,@A+
<base-reg>

Function: Move Code byte

Description: The MOVC instructions load the Accumulator with a code byte or constant from program memory. The address of the byte fetched is the sum of the original unsigned 8-bit Accumulator contents and the contents of a 16-bit base register, which may be either the Data Pointer or the PC. In the latter case, the PC is incremented to the address of the following instruction before being added with the Accumulator; otherwise the base register is not altered. Sixteen-bit addition is performed so a carry-out from the low-order eight bits may propagate through higher-order bits. No flags are affected.

Example: A value between 0 and 3 is in the Accumulator. The following instructions will translate the value in the Accumulator to one of four values defined by the DB (define byte) directive.

```
REL_PC:  INC    A
          MOVC  A,@A+PC
          RET
          DB    66H
          DB    77H
          DB    88H
          DB    99H
```

If the subroutine is called with the Accumulator equal to 01H, it returns with 77H in the Accumulator. The INC A before the MOVC instruction is needed to “get around” the RET instruction above the table. If several bytes of code separate the MOVC from the table, the corresponding number is added to the Accumulator instead.

MOVC A,@A+DPTR**Bytes:** 1**Cycles:** 2**Encoding:**

1	0	0	1	0	0	1	1
---	---	---	---	---	---	---	---

Operation: MOVC
(A) ← ((A) + (DPTR))**MOVC A,@A+PC****Bytes:** 1**Cycles:** 2**Encoding:**

1	0	0	0	0	0	1	1
---	---	---	---	---	---	---	---

Operation: MOVC
(PC) ← (PC) + 1
(A) ← ((A) + (PC))**1.14.32 MOVX <dest-byte>,<src-byte>****Function:** Move External**Description:** The MOVX instructions transfer data between the Accumulator and a byte of external data memory, which is why "X" is appended to MOV. There are two types of instructions, differing in whether they provide an 8-bit or 16-bit indirect address to the external data RAM.

In the first type, the contents of R0 or R1 in the current register bank provide an 8-bit address multiplexed with data on P0. Eight bits are sufficient for external I/O expansion decoding or for a relatively small RAM array. For somewhat larger arrays, any output port pins can be used to output higher-order address bits. These pins are controlled by an output instruction preceding the MOVX.

In the second type of MOVX instruction, the Data Pointer generates a 16-bit address. P2 outputs the high-order eight address bits (the contents of DPH), while P0 multiplexes the low-order eight bits (DPL) with data. The P2 Special Function Register retains its previous contents, while the P2 output buffers emit the contents of DPH. This form of MOVX is faster and more efficient when accessing very large data arrays (up to 64K bytes), since no additional instructions are needed to set up the output ports.

It is possible to use both MOVX types in some situations. A large RAM array with its high-order address lines driven by P2 can be addressed via the Data Pointer, or with code to output high-order address bits to P2, followed by a MOVX instruction using R0 or R1.

Example: An external 256 byte RAM using multiplexed address/data lines is connected to the 8051 Port 0. Port 3 provides control lines for the external RAM. Ports 1 and 2 are used for normal I/O. Registers 0 and 1 contain 12H and 34H. Location 34H of the external RAM holds the value 56H. The instruction sequence,

MOVX A,@R1

MOVX @R0,A

copies the value 56H into both the Accumulator and external RAM location 12H.

MOVX A,@R_i**Bytes:** 1**Cycles:** 2**Encoding:**

1	1	1	0	0	0	1	i
---	---	---	---	---	---	---	---

Operation: MOVX
 $(A) \leftarrow ((R_i))$

MOVX A,@DPTR

Bytes: 1

Cycles: 2

Encoding:

1	1	1	0	0	0	0	0
---	---	---	---	---	---	---	---

Operation: MOVX
 $(A) \leftarrow ((DPTR))$

MOVX @R_i,A

Bytes: 1

Cycles: 2

Encoding:

1	1	1	1	0	0	1	i
---	---	---	---	---	---	---	---

Operation: MOVX
 $((R_i)) \leftarrow (A)$

MOVX @DPTR,A

Bytes: 1

Cycles: 2

Encoding:

1	1	1	1	0	0	0	0
---	---	---	---	---	---	---	---

Operation: MOVX
 $(DPTR) \leftarrow (A)$

1.14.33 MUL AB

Function: Multiply

Description: MUL AB multiplies the unsigned 8-bit integers in the Accumulator and register B. The low-order byte of the 16-bit product is left in the Accumulator, and the high-order byte in B. If the product is greater than 255 (0FFH), the overflow flag is set; otherwise it is cleared. The carry flag is always cleared.

Example: Originally the Accumulator holds the value 80 (50H). Register B holds the value 160 (0A0H). The instruction,

MUL AB

will give the product 12,800 (3200H), so B is changed to 32H (00110010B) and the Accumulator is cleared. The overflow flag is set, carry is cleared.

Bytes: 1

Cycles: 4

Encoding:

1	0	1	0	0	1	0	0
---	---	---	---	---	---	---	---

Operation: MUL
 $(A)_{7-0} \leftarrow (A) \times (B)$
 $(B)_{15-8}$

1.14.34 NOP

Function: No Operation

Description: Execution continues at the following instruction. Other than the PC, no registers or flags are affected.

Example: A low-going output pulse on bit 7 of Port 2 must last exactly 5 cycles. A simple SETB/CLR sequence generates a one-cycle pulse, so four additional cycles must be inserted. This may be done (assuming no interrupts are enabled) with the following instruction sequence,

```
CLR      P2.7
NOP
NOP
NOP
NOP
SETB    P2.7
```

Bytes: 1

Cycles: 1

Encoding:

0	0	0	0	0	0	0	0
---	---	---	---	---	---	---	---

Operation: NOP
(PC) ← (PC) + 1

1.14.35 ORL<dest-byte>
<src-byte>

Function: Logical-OR for byte variables

Description: ORL performs the bitwise logical-OR operation between the indicated variables, storing the results in the destination byte. No flags are affected.

The two operands allow six addressing mode combinations. When the destination is the Accumulator, the source can use register, direct, register-indirect, or immediate addressing; when the destination is a direct address, the source can be the Accumulator or immediate data.

Note: When this instruction is used to modify an output port, the value used as the original port data is read from the output data latch, *not* the input pins.

Example: If the Accumulator holds 0C3H (11000011B) and R0 holds 55H (01010101B) then the following instruction,

```
ORL    A,R0
```

leaves the Accumulator holding the value 0D7H (11010111B). When the destination is a directly addressed byte, the instruction can set combinations of bits in any RAM location or hardware register. The pattern of bits to be set is determined by a mask byte, which may be either a constant data value in the instruction or a variable computed in the Accumulator at run-time. The instruction,

```
ORL    P1,#00110010B
```

sets bits 5, 4, and 1 of output Port 1.

ORL A,R_n

Bytes: 1

Cycles: 1

Encoding:

0	1	0	0	1	r	r	r
---	---	---	---	---	---	---	---

Operation: ORL
 $(A) \leftarrow (A) \vee (R_n)$

ORL A,direct

Bytes: 2

Cycles: 1

Encoding:

0	1	0	0	0	1	0	1
---	---	---	---	---	---	---	---

direct address

Operation: ORL
 $(A) \leftarrow (A) \vee (\text{direct})$

ORL A,@R_i

Bytes: 1

Cycles: 1

Encoding:

0	1	0	0	0	1	1	i
---	---	---	---	---	---	---	---

Operation: ORL
 $(A) \leftarrow (A) \vee ((R_i))$

ORL A,#data

Bytes: 2

Cycles: 1

Encoding:	0	1	0	0	0	1	0	0	immediate data
-----------	---	---	---	---	---	---	---	---	----------------

Operation: ORL
 $(A) \leftarrow (A) \vee \#data$

ORL direct,A

Bytes: 2

Cycles: 1

Encoding:	0	1	0	0	0	0	1	0	direct address
-----------	---	---	---	---	---	---	---	---	----------------

Operation: ORL
 $(direct) \leftarrow (direct) \vee (A)$

ORL direct,#data

Bytes: 3

Cycles: 2

Encoding:	0	1	0	0	0	0	1	1	direct addr.	immediate data
-----------	---	---	---	---	---	---	---	---	--------------	----------------

Operation: ORL
 $(direct) \leftarrow (direct) \vee \#data$

1.14.36 ORL C,<src-bit>

Function: Logical-OR for bit variables

Description: Set the carry flag if the Boolean value is a logical 1; leave the carry in its current state otherwise. A slash (/) preceding the operand in the assembly language indicates that the logical complement of the addressed bit is used as the source value, but the source bit itself is not affected. No other flags are affected.

Example: Set the carry flag if and only if P1.0 = 1, ACC. 7 = 1, or OV = 0:

```
MOV    C,P1.0    ;LOAD CARRY WITH INPUT PIN P10
ORL    C,ACC.7   ;OR CARRY WITH THE ACC. BIT 7
ORL    C,/OV     ;OR CARRY WITH THE INVERSE OF OV.
```

ORL C,bit

Bytes: 2

Cycles: 2

Encoding:	0	1	1	1	0	0	1	0	bit address
-----------	---	---	---	---	---	---	---	---	-------------

Operation: ORL
 $(C) \leftarrow (C) \vee (bit)$

ORL C,/bit

Bytes: 2

Cycles: 2

Encoding:

1	0	1	0	0	0	0	0
---	---	---	---	---	---	---	---

bit address

Operation: ORL
 $(C) \leftarrow (C) \vee \overline{(\text{bit})}$

1.14.37 POP direct

Function: Pop from stack.

Description: The contents of the internal RAM location addressed by the Stack Pointer is read, and the Stack Pointer is decremented by one. The value read is then transferred to the directly addressed byte indicated. No flags are affected.

Example: The Stack Pointer originally contains the value 32H, and internal RAM locations 30H through 32H contain the values 20H, 23H, and 01H, respectively. The following instruction sequence,

```
POP    DPH
POP    DPL
```

leaves the Stack Pointer equal to the value 30H and sets the Data Pointer to 0123H. At this point, the following instruction,

```
POP    SP
```

leaves the Stack Pointer set to 20H. In this special case, the Stack Pointer was decremented to 2FH before being loaded with the value popped (20H).

Bytes: 2

Cycles: 2

Encoding:

1	1	0	1	0	0	0	0
---	---	---	---	---	---	---	---

direct address

Operation: POP
 (direct) ← ((SP))
 (SP) ← (SP) - 1

1.14.38 PUSH direct

Function: Push onto stack

Description: The Stack Pointer is incremented by one. The contents of the indicated variable is then copied into the internal RAM location addressed by the Stack Pointer. Otherwise no flags are affected.

Example: On entering an interrupt routine, the Stack Pointer contains 09H. The Data Pointer holds the value 0123H. The following instruction sequence,

```
PUSH   DPL
PUSH   DPH
```

leaves the Stack Pointer set to 0BH and stores 23H and 01H in internal RAM locations 0AH and 0BH, respectively.

Bytes: 2

Cycles: 2

Encoding:

1	1	0	0	0	0	0	0
---	---	---	---	---	---	---	---

direct address

Operation: PUSH
 (SP) ← (SP) + 1
 ((SP)) ← (direct)

1.14.39 RET

Function: Return from subroutine

Description: RET pops the high- and low-order bytes of the PC successively from the stack, decrementing the Stack Pointer by two. Program execution continues at the resulting address, generally the instruction immediately following an ACALL or LCALL. No flags are affected.

Example: The Stack Pointer originally contains the value 0BH. Internal RAM locations 0AH and 0BH contain the values 23H and 01H, respectively. The following instruction,

RET

leaves the Stack Pointer equal to the value 09H. Program execution continues at location 0123H.

Bytes: 1

Cycles: 2

Encoding:

0	0	1	0	0	0	1	0
---	---	---	---	---	---	---	---

Operation: RET

$(PC_{15-8}) \leftarrow ((SP))$

$(SP) \leftarrow (SP) - 1$

$(PC_{7-0}) \leftarrow ((SP))$

$(SP) \leftarrow (SP) - 1$

1.14.40 RETI

Function: Return from interrupt

Description: RETI pops the high- and low-order bytes of the PC successively from the stack and restores the interrupt logic to accept additional interrupts at the same priority level as the one just processed. The Stack Pointer is left decremented by two. No other registers are affected; the PSW is *not* automatically restored to its pre-interrupt status. Program execution continues at the resulting address, which is generally the instruction immediately after the point at which the interrupt request was detected. If a lower- or same-level interrupt was pending when the RETI instruction is executed, that one instruction is executed before the pending interrupt is processed.

Example: The Stack Pointer originally contains the value 0BH. An interrupt was detected during the instruction ending at location 0122H. Internal RAM locations 0AH and 0BH contain the values 23H and 01H, respectively. The following instruction,

RETI

leaves the Stack Pointer equal to 09H and returns program execution to location 0123H.

Bytes: 1

Cycles: 2

Encoding:

0	0	1	1	0	0	1	0
---	---	---	---	---	---	---	---

Operation: RETI

$(PC_{15-8}) \leftarrow ((SP))$

$(SP) \leftarrow (SP) - 1$

$(PC_{7-0}) \leftarrow ((SP))$

$(SP) \leftarrow (SP) - 1$

1.14.41 RL A

Function: Rotate Accumulator Left

Description: The eight bits in the Accumulator are rotated one bit to the left. Bit 7 is rotated into the bit 0 position. No flags are affected.

Example: The Accumulator holds the value 0C5H (11000101B). The following instruction,

```
RL      A
```

leaves the Accumulator holding the value 8BH (10001011B) with the carry unaffected.

Bytes: 1

Cycles: 1

Encoding:

0	0	1	0	0	0	1	1
---	---	---	---	---	---	---	---

Operation: RL

$$(A_n + 1) \leftarrow (A_n) \quad n = 0 - 6$$

$$(A_0) \leftarrow (A_7)$$

1.14.42 RLC A

Function: Rotate Accumulator Left through the Carry flag

Description: The eight bits in the Accumulator and the carry flag are together rotated one bit to the left. Bit 7 moves into the carry flag; the original state of the carry flag moves into the bit 0 position. No other flags are affected.

Example: The Accumulator holds the value 0C5H(11000101B), and the carry is zero. The following instruction,

```
RLC     A
```

leaves the Accumulator holding the value 8BH (10001010B) with the carry set.

Bytes: 1

Cycles: 1

Encoding:

0	0	1	1	0	0	1	1
---	---	---	---	---	---	---	---

Operation: RLC

$$(A_n + 1) \leftarrow (A_n) \quad n = 0 - 6$$

$$(A_0) \leftarrow (C)$$

$$(C) \leftarrow (A_7)$$

1.14.43 RR A

Function: Rotate Accumulator Right

Description: The eight bits in the Accumulator are rotated one bit to the right. Bit 0 is rotated into the bit 7 position. No flags are affected.

Example: The Accumulator holds the value 0C5H (11000101B). The following instruction,

```
RR      A
```

leaves the Accumulator holding the value 0E2H (11100010B) with the carry unaffected.

Bytes: 1

Cycles: 1

Encoding:

0	0	0	0	0	0	1	1
---	---	---	---	---	---	---	---

Operation: RR

$$(A_n) \leftarrow (A_n + 1) \quad n = 0 - 6$$

$$(A_7) \leftarrow (A_0)$$

1.14.44 RRC A

Function: Rotate Accumulator Right through Carry flag

Description: The eight bits in the Accumulator and the carry flag are together rotated one bit to the right. Bit 0 moves into the carry flag; the original value of the carry flag moves into the bit 7 position. No other flags are affected.

Example: The Accumulator holds the value 0C5H (11000101B), the carry is zero. The following instruction,

```
RRC     A
```

leaves the Accumulator holding the value 62 (01100010B) with the carry set.

Bytes: 1

Cycles: 1

Encoding:

0	0	0	1	0	0	1	1
---	---	---	---	---	---	---	---

Operation: RRC

$$(A_n) \leftarrow (A_n + 1) \quad n = 0 - 6$$

$$(A_7) \leftarrow (C)$$

$$(C) \leftarrow (A_0)$$

1.14.45 SETB<bit>

Function: Set Bit

Description: SETB sets the indicated bit to one. SETB can operate on the carry flag or any directly addressable bit. No other flags are affected.

Example: The carry flag is cleared. Output Port 1 has been written with the value 34H (00110100B). The following instructions,

```
SETB    C
SETB    P1.0
```

sets the carry flag to 1 and changes the data output on Port 1 to 35H (00110101B).

SETB C

Bytes: 1

Cycles: 1

Encoding:

1	1	0	1	0	0	1	1
---	---	---	---	---	---	---	---

Operation: SETB
(C) ← 1

SETB bit

Bytes: 2

Cycles: 1

Encoding:

1	1	0	1	0	0	1
---	---	---	---	---	---	---

 0

bit address

Operation: SETB
(bit) ← 1

1.14.46 SJMP rel

Function: Short Jump

Description: Program control branches unconditionally to the address indicated. The branch destination is computed by adding the signed displacement in the second instruction byte to the PC, after incrementing the PC twice. Therefore, the range of destinations allowed is from 128 bytes preceding this instruction 127 bytes following it.

Example: The label RELADR is assigned to an instruction at program memory location 0123H. The following instruction,

```
SJMP    RELADR
```

assembles into location 0100H. After the instruction is executed, the PC contains the value 0123H.

Note: Under the above conditions the instruction following SJMP is at 102H. Therefore, the displacement byte of the instruction is the relative offset (0123H-0102H) = 21H. Put another way, an SJMP with a displacement of 0FEH is a one-instruction infinite loop.

Bytes: 2

Cycles: 2

Encoding:

1	0	0	0	0	0	0	0
---	---	---	---	---	---	---	---

rel. address

Operation: SJMP
(PC) ← (PC) + 2
(PC) ← (PC) + rel

1.14.47 SUBB A,<src-byte>

Function: Subtract with borrow

Description: SUBB subtracts the indicated variable and the carry flag together from the Accumulator, leaving the result in the Accumulator. SUBB sets the carry (borrow) flag if a borrow is needed for bit 7 and clears C otherwise. (If C was set *before* executing a SUBB instruction, this indicates that a borrow was needed for the previous step in a multiple-precision subtraction, so the carry is subtracted from the Accumulator along with the source operand.) AC is set if a borrow is needed for bit 3 and cleared otherwise. OV is set if a borrow is needed into bit 6, but not into bit 7, or into bit 7, but not bit 6.

When subtracting signed integers, OV indicates a negative number produced when a negative value is subtracted from a positive value, or a positive result when a positive number is subtracted from a negative number.

The source operand allows four addressing modes: register, direct, register-indirect, or immediate.

Example: The Accumulator holds 0C9H (11001001B), register 2 holds 54H (01010100B), and the carry flag is set. The instruction,

SUBB A,R2

will leave the value 74H (01110100B) in the accumulator, with the carry flag and AC cleared but OV set.

Notice that 0C9H minus 54H is 75H. The difference between this and the above result is due to the carry (borrow) flag being set before the operation. If the state of the carry is not known before starting a single or multiple-precision subtraction, it should be explicitly cleared by CLR C instruction.

SUBB A,R_n

Bytes: 1

Cycles: 1

Encoding:

1	0	0	1	1	r	r	r
---	---	---	---	---	---	---	---

Operation: SUBB
(A) ← (A) - (C) - (R_n)

SUBB A,direct

Bytes: 2

Cycles: 1

Encoding:

1	0	0	1	0	1	0	1
---	---	---	---	---	---	---	---

direct address

Operation: SUBB
(A) ← (A) - (C) - (direct)

SUBB A,@R_i

Bytes: 1

Cycles: 1

Encoding:

1	0	0	1	0	1	1	i
---	---	---	---	---	---	---	---

Operation: SUBB
(A) ← (A) - (C) - ((R_i))

SUBB A,#data**Bytes:** 2**Cycles:** 1**Encoding:**

1	0	0	1	0	1	0	0
---	---	---	---	---	---	---	---

immediate data

Operation: SUBB
(A) ← (A) - (C) - #data**1.14.48 SWAP A****Function:** Swap nibbles within the Accumulator**Description:** SWAP A interchanges the low- and high-order nibbles (four-bit fields) of the Accumulator (bits 3 through 0 and bits 7 through 4). The operation can also be thought of as a 4-bit rotate instruction. No flags are affected.**Example:** The Accumulator holds the value 0C5H (11000101B). The instruction,

SWAP A

leaves the Accumulator holding the value 5CH (01011100B).

Bytes: 1**Cycles:** 1**Encoding:**

1	1	0	0	0	1	0	0
---	---	---	---	---	---	---	---

Operation: SWAP
(A₃₋₀) D (A₇₋₄)**1.14.49 XCH A,<byte>****Function:** Exchange Accumulator with byte variable**Description:** XCH loads the Accumulator with the contents of the indicated variable, at the same time writing the original Accumulator contents to the indicated variable. The source/destination operand can use register, direct, or register-indirect addressing.**Example:** R0 contains the address 20H. The Accumulator holds the value 3FH (00111111B). Internal RAM location 20H holds the value 75H (01110101B). The following instruction,

XCH A,@R0

leaves RAM location 20H holding the values 3FH (00111111B) and 75H (01110101B) in the accumulator.

XCH A,R_n**Bytes:** 1**Cycles:** 1**Encoding:**

1	1	0	0	1	r	r	r
---	---	---	---	---	---	---	---

Operation: XCH
(A) D ((R_n))**XCH A,direct**

Bytes: 2

Cycles: 1

Encoding:

1	1	0	0	0	1	0	1
---	---	---	---	---	---	---	---

direct address

Operation: XCH
(A) D (direct)

XCH A,@R_i

Bytes: 1

Cycles: 1

Encoding:

1	1	0	0	0	1	1	i
---	---	---	---	---	---	---	---

Operation: XCH
(A) D ((R_i))

1.14.50 XCHD A,@R_i

Function: Exchange Digit

Description: XCHD exchanges the low-order nibble of the Accumulator (bits 3 through 0), generally representing a hexadecimal or BCD digit, with that of the internal RAM location indirectly addressed by the specified register. The high-order nibbles (bits 7-4) of each register are not affected. No flags are affected.

Example: R0 contains the address 20H. The Accumulator holds the value 36H (00110110B). Internal RAM location 20H holds the value 75H (01110101B). The following instruction,

XCHD A,@R0

leaves RAM location 20H holding the value 76H (01110110B) and 35H (00110101B) in the Accumulator.

Bytes: 1

Cycles: 1

Encoding:

1	1	0	1	0	1	1	i
---	---	---	---	---	---	---	---

Operation: XCHD
(A₃₋₀) D ((R_{i3-0}))

1.14.51 XRL <dest-byte>,<src-byte>

Function: Logical Exclusive-OR for byte variables

Description: XRL performs the bitwise logical Exclusive-OR operation between the indicated variables, storing the results in the destination. No flags are affected.

The two operands allow six addressing mode combinations. When the destination is the Accumulator, the source can use register, direct, register-indirect, or immediate addressing; when the destination is a direct address, the source can be the Accumulator or immediate data.

Note: When this instruction is used to modify an output port, the value used as the original port data is read from the output data latch, *not* the input pins.

Example: If the Accumulator holds 0C3H (11000011B) and register 0 holds 0AAH (10101010B) then the instruction,

```
XRL    A,R0
```

leaves the Accumulator holding the value 69H (01101001B).

When the destination is a directly addressed byte, this instruction can complement combinations of bits in any RAM location or hardware register. The pattern of bits to be complemented is then determined by a mask byte, either a constant contained in the instruction or a variable computed in the Accumulator at run-time. The following instruction,

```
XRL    P1,#00110001B
```

complements bits 5, 4, and 0 of output Port 1.

XRL A,R_n

Bytes: 1

Cycles: 1

Encoding:

0	1	1	0	1	r	r	r
---	---	---	---	---	---	---	---

Operation: XRL
(A) ← (A) ∨ (R_n)

XRL A,direct

Bytes: 2

Cycles: 1

Encoding:

0	1	1	0	0	1	0	1
---	---	---	---	---	---	---	---

direct address

Operation: XRL
(A) ← (A) ∨ (direct)

XRL A,@R_i

Bytes: 1

Cycles: 1

Encoding:

0	1	1	0	0	1	1	i
---	---	---	---	---	---	---	---

Operation: XRL
(A) ← (A) ∨ (R_i)

XRL A,@#data

Bytes: 2

Cycles: 1

Encoding:

0	1	1	0	0	1	0	0
---	---	---	---	---	---	---	---

immediate data

Operation: XRL
 $(A) \leftarrow (A) \vee \#data$

XRL direct,A

Bytes: 2

Cycles: 1

Encoding:

0	1	1	0	0	0	1	0
---	---	---	---	---	---	---	---

direct address

Operation: XRL
 $(direct) \leftarrow (direct) \vee (A)$

XRL direct,#data

Bytes: 3

Cycles: 2

Encoding:

0	1	1	0	0	0	1	1
---	---	---	---	---	---	---	---

direct address

immediate data

Operation: XRL
 $(direct) \leftarrow (direct) \vee \#data$



Section 2

Common Features Description

- 2.1 Introduction** This chapter presents a comprehensive description of the on-chip hardware features of the Atmel 8051 microcontrollers. Included in this description are:
- The port drivers and how they function both as ports and, for Ports 0 and 2, in bus operations
 - The Timer/Counters
 - The serial Interface
 - The Interrupt System
 - Reset
 - The reduced Power Modes

Figure 2-1. 8051 Architecture Block Diagram

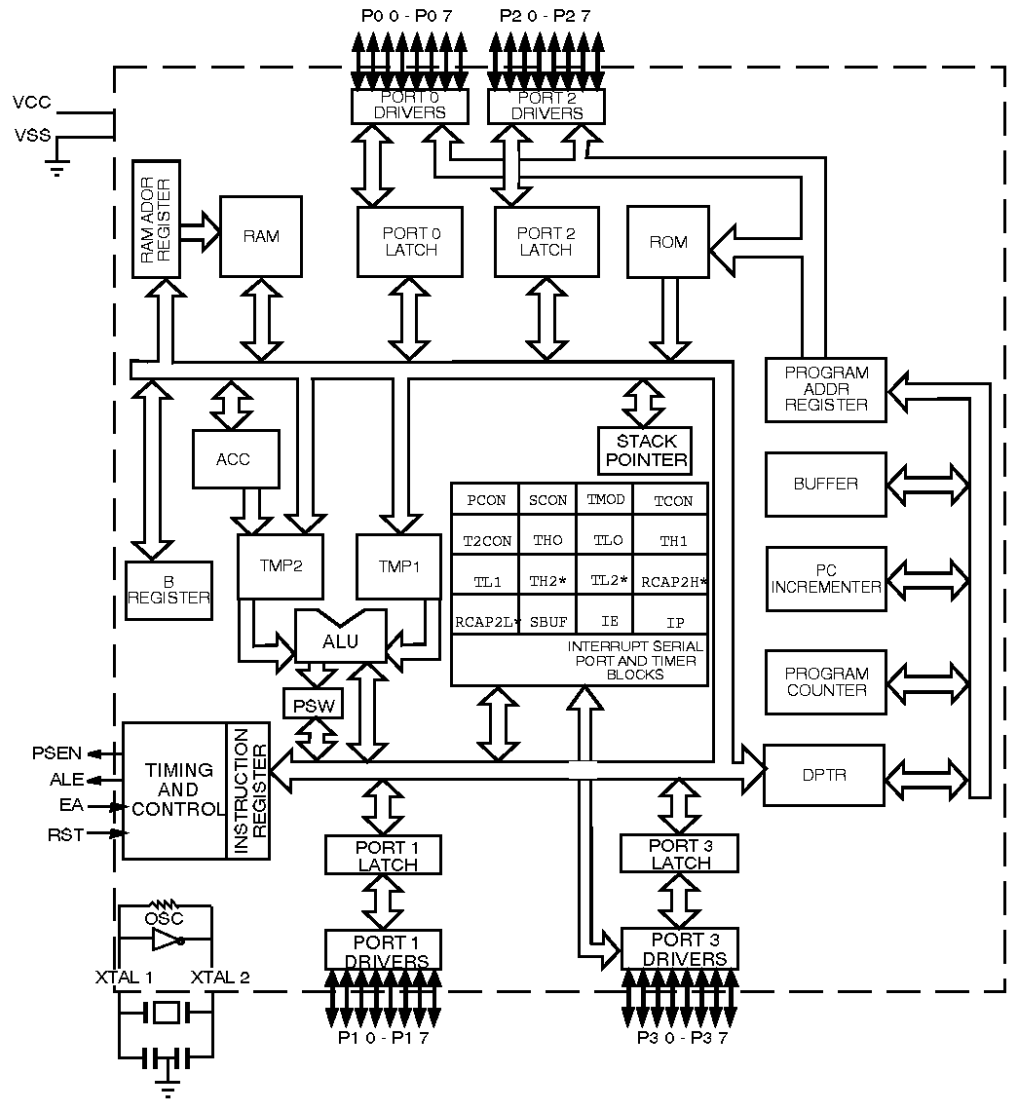

Note: (*)For Timer 2 only.

Figure 2-1 shows a functional block diagram of the 80C51s.

- 2.2 Special Function Registers** A map of the on-chip memory area called SFR (Special Function Register) space is shown in Figure 2-1. SFRs marked by parentheses are resident in the microcontroller which have the Timer2 feature. Note that not all of the addresses are occupied. Read accesses to these addresses will in general return random data.

	Bit Addressable	8 Bytes Non-bit Addressable							
F8h									FFh
F0h	B								F7h
E8h									EFh
E0h	ACC								E7h
D8h									DFh
D0h	PSW								D7h
C8h	(T2CON)		(RCAP2L)	(RCAP2H)	(TL2)	(TH2)			CFh
C0h									C7h
B8h	IP								BFh
B0h	P3								B7h
A8h	IE								AFh
A0h	P2								A7h
98h	SCON	SBUF							9Fh
90h	P1								97h
88h	TCON	TMOD	TL0	TL1	TH0	TH1	AUXR	CKCON	8Fh
80h	P0	SP	DPL	DPH				PCON	87h
	0/8	1/9	2/A	3/B	4/C	5/D	6/E	7/F	

Note: Reserved 

User software should not write to the reserved locations, since they may be used in derivative Atmel 8051 products to invoke new features. The functions of the SFRs are described as below.

- 2.2.1 Accumulator** ACC is the Accumulator register. The mnemonics for accumulator-specific instructions, however, refer to the accumulator simply as A.
- 2.2.2 B Register** The B register is used during multiply and divide operations. For other instructions it can be treated as another scratch pad register.

2.2.3 Program Status Word

The PSW register contains program status information as detailed in Table 2-1.

Table 2-1. PSW: Program Status Word Register

(MSB)				(LSB)			
CY	AC	F0	RS1	RS0	OV	-	P
Symbol	Position	Name and Significance					
CY	PSW.7	Carry flag					
AC	PSW.6	Auxiliary Carry flag. (For BCD operations.)					
F0	PSW.5	Flag 0 (Available to the user for general purposes.)					
RS1	PSW.4	Register bank Select control bits 1 & 0. Set/cleared by software to determine working register bank (see Note).					
RS0	PSW.3						
OV	PSW.2	Overflow flag.					
-	PSW.1	(reserved)					
P	PSW.0	Parity flag. Set/cleared by hardware each instruction cycle to indicate and odd/even number of "one" bits in the accumulator, i.e., even parity.					
Note: The contents of (RS1, RS0) enable the working register banks as follows (0.0)-Bank 0(00H-07H) (0.1)-Bank 1(08H-0FH) (1.0)-Bank 2(10H-17H) (1.1)-Bank 3(18H-1FH)							

2.2.4 Stack Pointer

The Stack Pointer register is 8 bits wide. It is incremented before data is stored during PUSH and CALL executions. While the stack may reside anywhere in on-chip RAM, the Stack Pointer is initialized to 07H after a reset. This causes the stack to begin at location 08H.

2.2.5 Data Pointer

The Data Pointer (DPTR) consists of a high byte (DPH) and a low byte (DPL). Its intended function is to hold a 16-bit address. It may be manipulated as a 16-bit register or as two independent 8-bit registers.

2.2.6 Ports 0 to 3

P0, P1, P2 and P3 are the SFR latches of Ports 0, 1, 2 and 3, respectively.

2.2.7 Serial Data Buffer

The Serial Data Buffer is actually two separate registers, a transmit buffer and a receive buffer register. When data is moved to SBUF, it goes to the transmit buffer where it is held for serial transmission. (Moving a byte to SBUF is what initiates the transmission.) When data is moved from SBUF, it comes from the receive buffer.

2.2.8 Timer Registers

Register pairs (TH0, TL0), (TH1, TL1), and (TH2, TL2) are the 16-bit counting registers for Timer/Counters 0, 1, and 2, respectively.

2.2.9 Capture Registers

The register pair (RCAP2H, RCAP2L) are the capture register for the Timer 2 'capture mode'. In this mode, in response to a transition at the 80C52's T2EX pin, TH2 and TL2 are copied into RCAP2H and RCAP2L. Timer 2 also has a 16-bit auto-reload mode, and

RCAP2H and RCAP2L hold the reload value for this mode. More about Timer 2's features in Section 1.6.

2.2.10 Control Registers

Special Function Registers IP, IE, TMOD, TCON, T2CON, SCON, and PCON contain control and status bits for the interrupt system, the timer/counters, and the serial port. They are described in later sections.

2.3 Oscillator and Clock Circuit

XTAL1 and XTAL2 are the input and output of a single-stage on-chip inverter, which can be configured with off-chip components as a Pierce oscillator, as shown in Figure 2-2. The on-chip circuitry, and selection of off-chip components to configure the oscillator are discussed in Section 1.12.

Figure 2-2. Crystal/Ceramic Resonator Oscillator

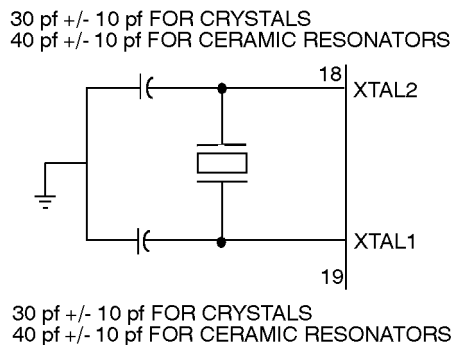

The oscillator, in any case, drives the internal clock generator. The clock generator provides the internal clocking signals to the chip. The internal clocking signals are at half the oscillator frequency, and define the internal phases, states, and machine cycles, which are described in the next section.

2.3.1 More about the On-chip Oscillator

This section not yet available.

2.4 CPU Timing

2.4.1 X1 Mode (Standard Mode)

A machine cycle consists of 6 states (12 oscillator periods). Each state is divided into a Phase 1 half, during which the Phase 1 clock is active, and a Phase 2 half, during which the Phase 2 clock is active. Thus, a machine cycle consists of 12 oscillator periods, numbered S1P1 (State 1, Phase 1), through S6P2 (State 6, Phase 2). Each phase lasts for one oscillator period. Each state lasts for two oscillator periods. Typically, arithmetic and logical operations take place during Phase 1 and internal register-to-register transfers take place during Phase 2.

The diagrams in Figure 2-3 show the fetch/execute timing referenced to the internal states and phases. Since these internal clock signals are not user accessible, the XTAL2 oscillator signal and the ALE (Address Latch Enable) signal are shown for external reference. ALE is normally activated twice during each machine cycle: once during S1P2 and S2P1, and again during S4P2 and S5P1.

Execution of one-cycle instruction begins at S1P2, when the opcode is latched into the Instruction Register. If it is a two-byte instruction, the second byte is read during S4 of the same machine cycle. If it is one-byte instruction, there is still a fetch at S4, but the byte read (which would be the next opcode), is ignored, and the Program Counter is not incremented. In any case, execution is complete at the end of S6P2. Figure 2-3A and Figure 2-3B show the timing for a 1-byte, 1-cycle instruction and for a 2-byte, 1-cycle instruction.

Most 80C51 instructions execute in one cycle. MUL (multiply) and DIV (divide) are the only instructions that take more than two cycles to complete. They take four cycles.

Separately, two codes bytes are fetched from Program Memory during every machine cycle. The only exception to this is when a MOVX instruction is executed. MOVX is a 1-byte 2-cycle instruction that accesses external Data Memory. During a MOVX, two fetches are skipped while the external Data Memory is being addressed and strobed. Figure 2-3C and Figure 2-3D show the timing for a normal 1-byte, 2-cycle instruction and for a MOVX instruction.

Figure 2-3. 80C51 Fetch/Execute Sequences.

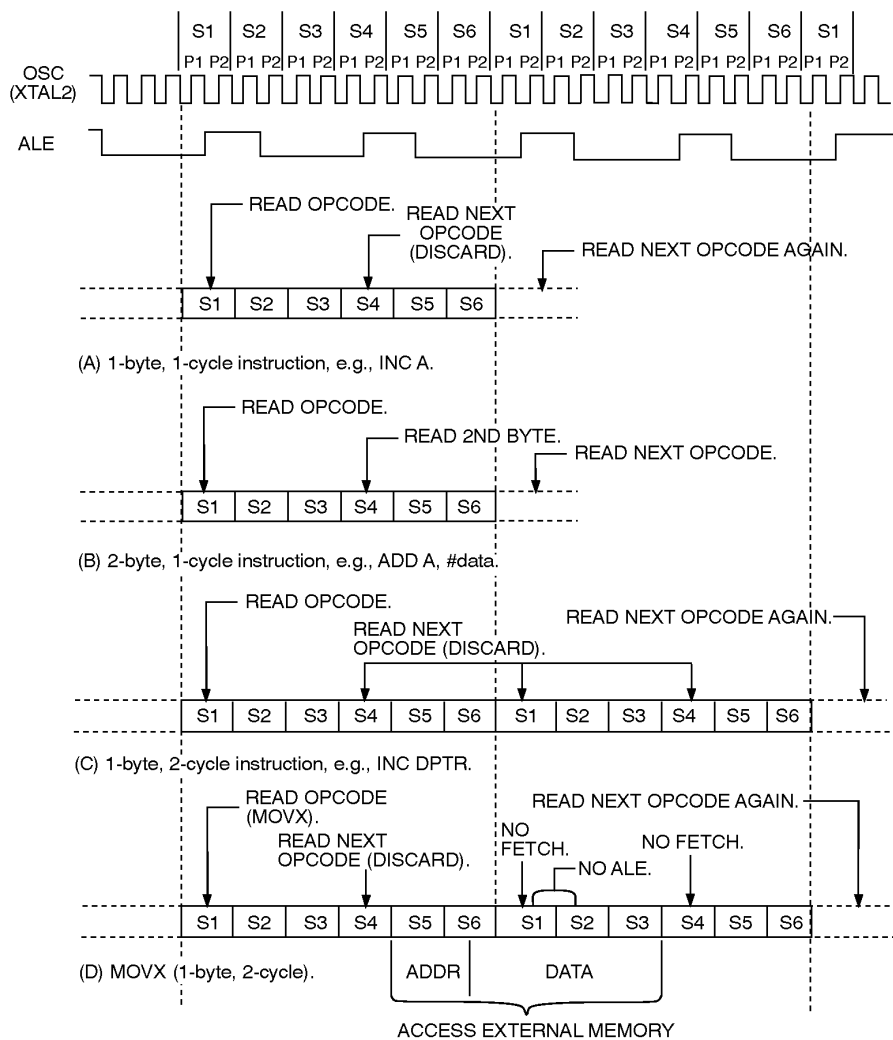

2.4.2 X2 Mode

This section not yet available.

2.5 Port Structures and Operation

All four ports in the 80C51 are bidirectional. Each consists of a latch (Special Function Register P0 through P3), an output driver, and an input buffer.

The output drivers of Ports 0 and 2, and input buffers of Port 0, are used in accesses to external memory. In this application, Port 0 outputs the low byte of the external memory address, time-multiplexed with the byte being written or read. Port 2 outputs the high byte of the external memory address when the address is 16 bits wide. Otherwise the Port 2 pins continue to emit the P2 SFR content.

All the Port 3 pins, and (in the case of Timer2) two Port 1 pins are multifunctional. They are not only port pins, but also serve the functions of various special features as listed below:

Port Pin	Alternate Function
⁽¹⁾ P1.0	T2 (Timer/Counter 2 external input) (If Timer 2 available)
⁽¹⁾ P1.1	T2EX (Timer/Counter 2 capture/reload trigger) (If Timer 2 available)
P3.0	RXD (serial input port)
P3.1	TXD (serial output port)
P3.2	$\overline{\text{INT0}}$ (external interrupt)
P3.3	$\overline{\text{INT1}}$ (external interrupt)
P3.4	T0 (Timer/Counter 0 external input)
P3.5	T1 (Timer/Counter 1 external input)
P3.6	$\overline{\text{WR}}$ (external Data memory write strobe)
P3.7	$\overline{\text{RD}}$ (external Data memory read strobe)

The alternate functions can only be activated if the corresponding bit latch in the port SFR contains a 1. Otherwise the port pin is stuck at 0.

2.5.1 I/O Configurations

Figure 2-4 shows a functional diagram of a typical bit latch and I/O buffer in each of the four ports. The bit latch (one bit in the port's SFR) is represented as a Type D flip-flop, which will clock in a value from the internal bus in response to a "write to latch" signal from the CPU. The Q output of the flip-flop is placed on the internal bus in response to a "read latch" signal from the CPU. The level of the port pin itself is placed on the internal bus in response to a "read pin" signal from the CPU. Some instructions that read a port activate the "read latch" signal, and others activate the "read pin" signal, and others activate the "read pin" signal.

Figure 2-4. 80C51 Port Bit Latches and I/O Buffers.

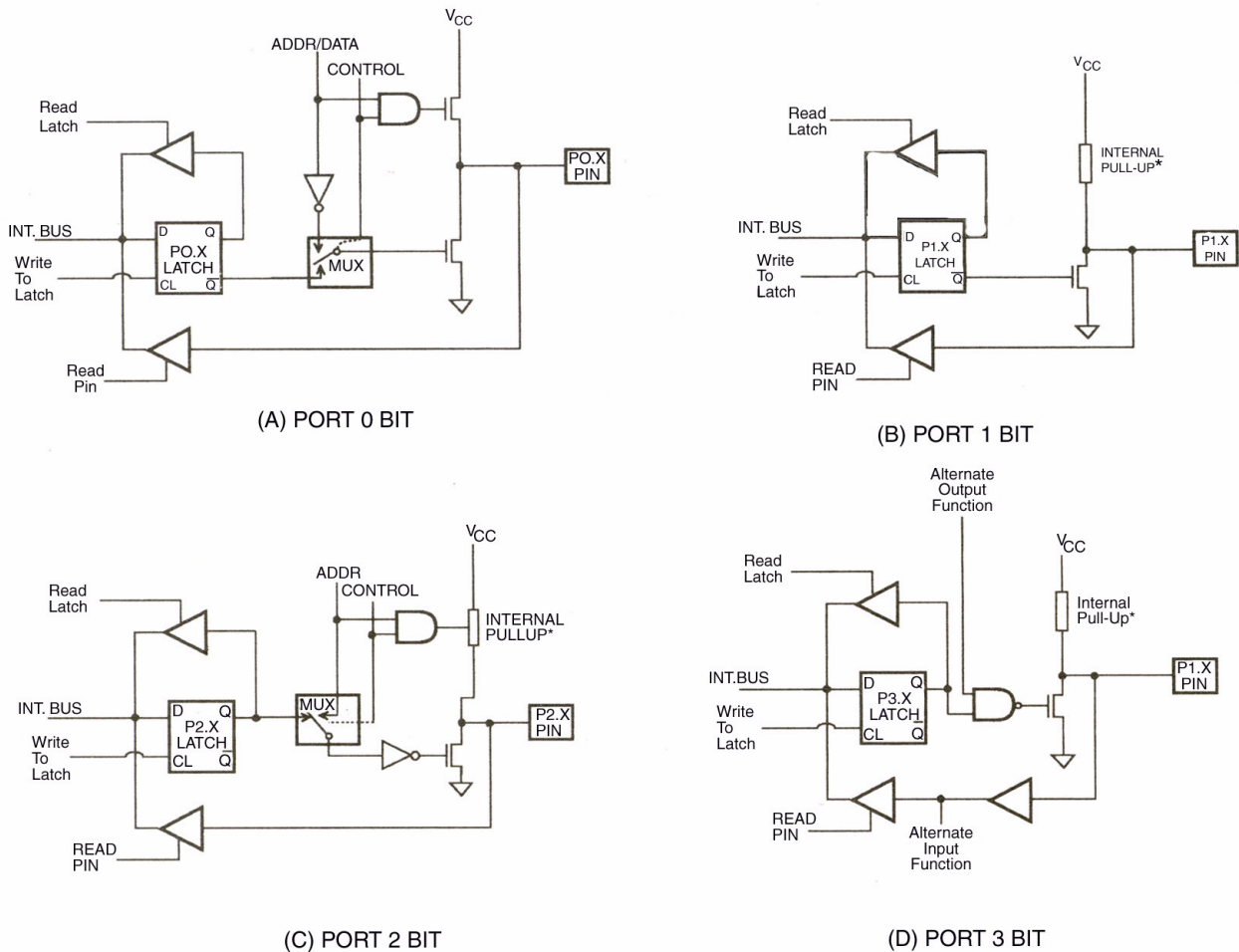

As shown in Figure 2-4, the output drivers of Ports 0 and 2 are switchable to an internal ADDR and ADDR/DATA bus by an internal CONTROL signal for use in external memory accesses. During external memory accesses, the P2 SFR remains unchanged, but the P0 SFR gets 1s written to it.

Also shown in Figure 2-4, is that if a P3 bit latch contains a 1, then the output level is controlled by the signal labeled “alternate output function.” The actual P3.X pin level is always available to the pin’s alternate input function, if any.

Ports 1, 2, and 3 have internal pull-ups. Port 0 has open-drain outputs. Each I/O line can be independently used as an input or an output. (Ports 0 and 2 may not be used as general purpose I/O when being used as the ADDR/DATA BUS). To be used as an input, the port bit latch must contain a 1, which turns off the output driver FET. Then, for Ports 1, 2, and 3, the pin is pulled high by the internal pull-up, but can be pulled low by an external source.

Port 0 differs in not having internal pull-ups. The pull-up FET in the P0 output driver (see Figure 2-4A) is used only when the Port is emitting 1’s during external memory accesses. Otherwise the pull-up FET is off. Consequently P0 lines that are being used as output port lines are open drain. Writing a 1 to the bit latch leaves both output FETs off, so the pin floats. In that conditions it can be used as a high-impedance input.

Because Ports 1, 2, and 3 have fixed internal pull-ups they are sometimes called “quasi-bidirectional” ports. When configured as inputs they pull high and will source current (IIL,

in the data sheets) when externally pulled low. Port 0, on the other hand, is considered “true” bidirectional, because when configured as an input it floats.

All the port latches in the 80C51 have 1’s written to them by the reset function. If a 0 is subsequently written to a port latch, it can be re configured as an input by writing a 1 to it.

2.5.2 Writing to a Port

In the execution of an instruction that changes the value in a port latch, the new value arrives at the latch during S6P2 of the final cycle of the instruction. However, port latches are in fact sampled by their output buffers only during Phase 1 of any clock period. (During Phase 2 the output buffer holds the value it saw during the previous Phase 1). Consequently, the new value in the port latch won’t actually appear at the output pin until the next Phase 1, which be at S1P1 of the next machine cycle.

If the change requires a 0-to-1 transition in Port 1, 2, or 3, an additional pull-up is turned on during S1P1 and S1P2 of the cycle in which the transition occurs. This is done to increase the transition speed. The extra pull-up can source about 100 times the current that the normal pull-up can. It should be noted that the internal pull-ups are field-effect transistors, not linear resistors. The pull-up arrangements are shown in Figure 2-5.

In the CMOS versions, the pull-up consists of three pFETs. It should be noted that an n-channel FET (nFET) is turned on when a logical 1 is applied to its gate, and is turned off when a logical 0 is applied to its gate. A p-channel FET (pFET) is the opposite: it is on when its gate sees a 0, and off when its gate sees a 1.

pFET 1 in Figure 2-5 is the transistor that is turned on 2 oscillator periods after a 0-to-1 transition in the port latch. While it’s on, it turns on pFET 3 (a weak pull-up), through the inverter. This inverter and pFET form a latch which hold the 1.

Note that if the pin is emitting a 1, a negative glitch on the pin from some external source can turn off pFET 3, causing the pin to go into a float state, pFET 2 is a very weak pull-up which is on whenever the nFET is off, in traditional CMOS style. It’s only about 1/10 the strength of pFET3. Its function is to restore a 1 to the pin in the event the pin had a 1 and lost it to a glitch.

Figure 2-5. Ports 1 and 3 CMOS Internal Pull-up Configurations.

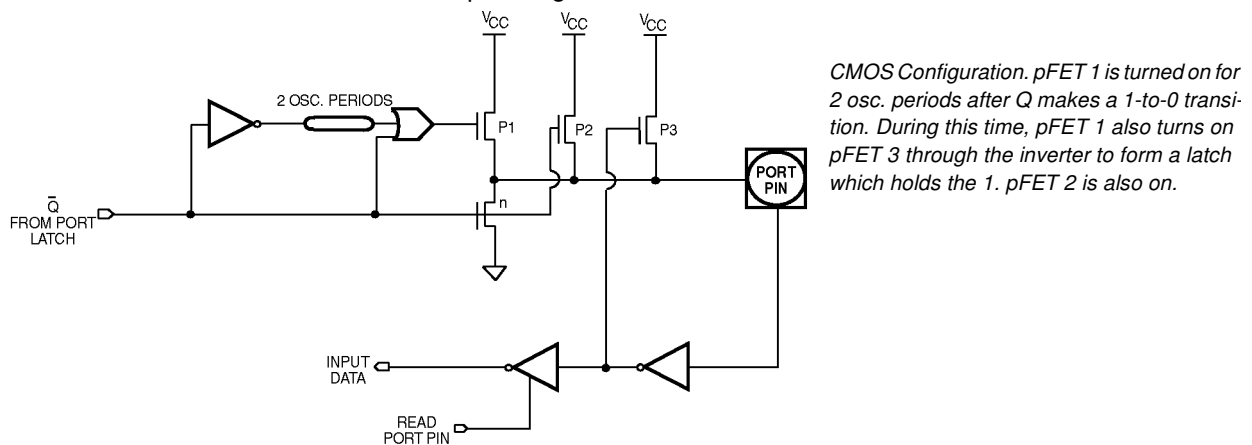

CMOS Configuration. pFET 1 is turned on for 2 osc. periods after Q makes a 1-to-0 transition. During this time, pFET 1 also turns on pFET 3 through the inverter to form a latch which holds the 1. pFET 2 is also on.

Port 2 is similar except that it holds the strong pull-up on while emitting 1s that are address bits. (See “Accessing External Memory”.)

2.5.3 Port Loading and Interfacing

The output buffer of Ports 1, 2 and 3 can each drive 3LS TTL inputs. The pins can be driven by open-collector and open-drain outputs, but note that 0-to-1 transition will not be fast. In the CMOS device, an input 0 turns off pull-up P3, leaving only the weak pull-up P2 to drive the transistor. Figure 2-6 shows an example where the port is driven by an open drain transistor t_N . The parasitic capacitance is equal to 1000pF.

Figure 2-6. Port Interfacing

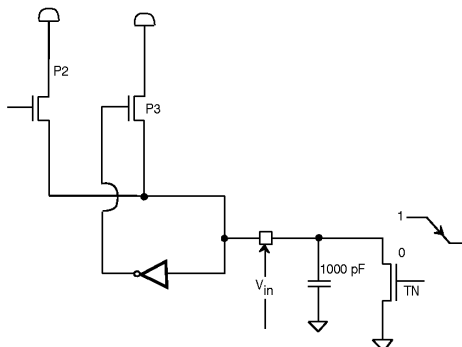

The above diagram show the behavior of the port during 0 to 1 transition.

In the area A only pull-up P2 sinks the capacitor and takes 5 μ s to switch from 0 volt to 2 volts. In the area B, pull-up P2 and P3 feed the capacitor and the time to charge the capacitor is divide roughly by ten. So this figure shows it takes some machine cycles before having a true high level during a 0-to-1 transition.

Figure 2-7. Port Behavior During 0-to-1 Transition

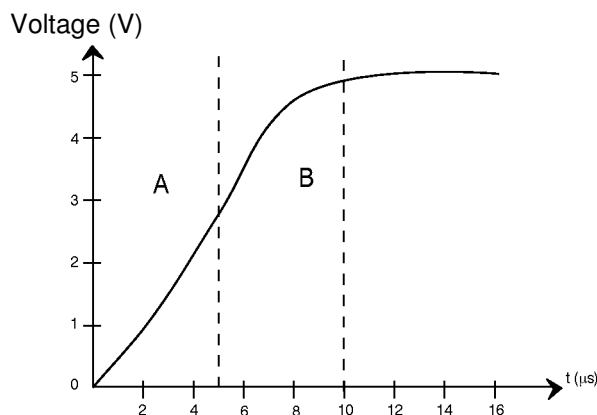

2.5.4 Read-Modify-Write Feature

Some instructions that read a port read the latch and others read the pin. Which instructions perform what functions? The instructions that read the latch rather than the pin are the ones that read a value, possibly change it, and then rewrite it to the latch. These are called “read-modify-write” instructions. The instructions listed below are read-modify-write instructions. When the destination operand is a port, or a port bit, these instructions read the latch rather than the pin:

ANL	(logical AND, e.g., ANL P1,A)
ORL	(logical OR, e.g., ORL P2,A)
XRL	(logical EX-OR, e.g., XRL P3,A)
JBC	(jump if bit = 1 and clear bit, e.g., JBC P1.1, LABEL)
CPL	(complement bit, e.g., CPL P3.0)
INC	(increment, e.g., INC P2)
DEC	(decrement, e.g., DEC P2)

DJNZ (decrement and jump if not zero, e.g., DJNZ P3, LABEL)
 MOV PX.Y,C(move carry bit to bit Y of Port X)
 CLR PX.Y(clear bit Y of Port X)
 SETB PX.Y(set bit Y of Port X)

It is not obvious that the last three instructions in this list are read-modify-write instructions, but they are. They read the port byte, all 8 bits, modify the addressed bit, then write the new byte back to the latch.

The reason that read-modify-write instructions are directed to the latch rather than the pin is to avoid a possible misinterpretation of the voltage level at the pin. For example, a port bit might be used to drive the base of a transistor. When a 1 is written to the bit, the transistor is turned on. If the CPU then reads the same port bit at the pin rather than the latch, it will read the base voltage of the transistor and interpret it as a 0. Reading the latch rather than the pin will return the correct value of 1.

2.6 Accessing External Memory

Accesses to external memory are of two types: accesses to external Program Memory and accesses to external Data Memory. Accesses to external Program Memory use signal $\overline{\text{PSEN}}$ (program store enable) as the read strobe. Accesses to external Data Memory use $\overline{\text{RD}}$ or $\overline{\text{WR}}$ (alternate function of P3.7 and P3.6) to strobe the memory.

Fetches from external Program memory always use a 16-bit address. Accesses to external Data Memory can use either a 16-bit address (MOVX @DPTR) or an 8-bit address (MOVX @Ri).

Whenever a 16-bit address is used, the high byte of the address comes out on Port 2, where it is held for the duration of the read or write cycle. Note that the Port 2 drivers use the strong pull-ups during the entire time that they are emitting address bits that are 1's. This is during the execution of a MOVX @DPTR instruction. During this time the Port 2 latch (the Special Function register) does not have to contain 1's, and the contents of the Port 2 SFR are not modified. If the external memory cycle is not immediately followed by another external memory cycle, the undisturbed contents of the Port 2 SFR will reappear in the next cycle.

If an 8-bit address is being used (MOVX @Ri), the contents of the Port 2 SFR remain at the Port 2 pins throughout the external memory cycle. This will facilitate paging.

In any case, the low byte of the address is time-multiplexed with the data byte on Port 0. The ADDR/DATA signal drives both FETs in the Port 0 output buffers. Thus, in this application the Port 0 pins are not open-drain outputs, and do not require external pull-ups. Signal ALE (address latch enable) should be used to capture the address byte into an external latch. The address byte is valid at the negative transitions of ALE. Then, in a write cycle, the data byte to be written appears on Port 0 just before $\overline{\text{WR}}$ is activated, and remains there until after $\overline{\text{WR}}$ is deactivated. In a read cycle, the incoming byte is accepted at Port 0 just before the read strobe is deactivated.

During any access to external memory, the CPU writes 0FFH to the Port 0 latch (the Special Function Register), thus obliterating whatever information the Port 0 SFR may have been holding.

External program Memory is accessed under two conditions:

1. Whenever signal $\overline{\text{EA}}$ is active or
2. Whenever the program counter (PC) contains a number that is larger than the memory size.

This requires that the ROMless versions have $\overline{\text{EA}}$ wired low to enable the lower program bytes to be fetched from external memory.

When the CPU is executing out of external Program Memory, all 8 bits of Port 2 are dedicated to an output function and may not be used for general purpose I/O. During external program fetches they output the high byte of the PC. During this time the Port 2 drivers use the strong pull-ups to emit PC bits that are 1's.

Figure 2-8. External Program Memory Execution

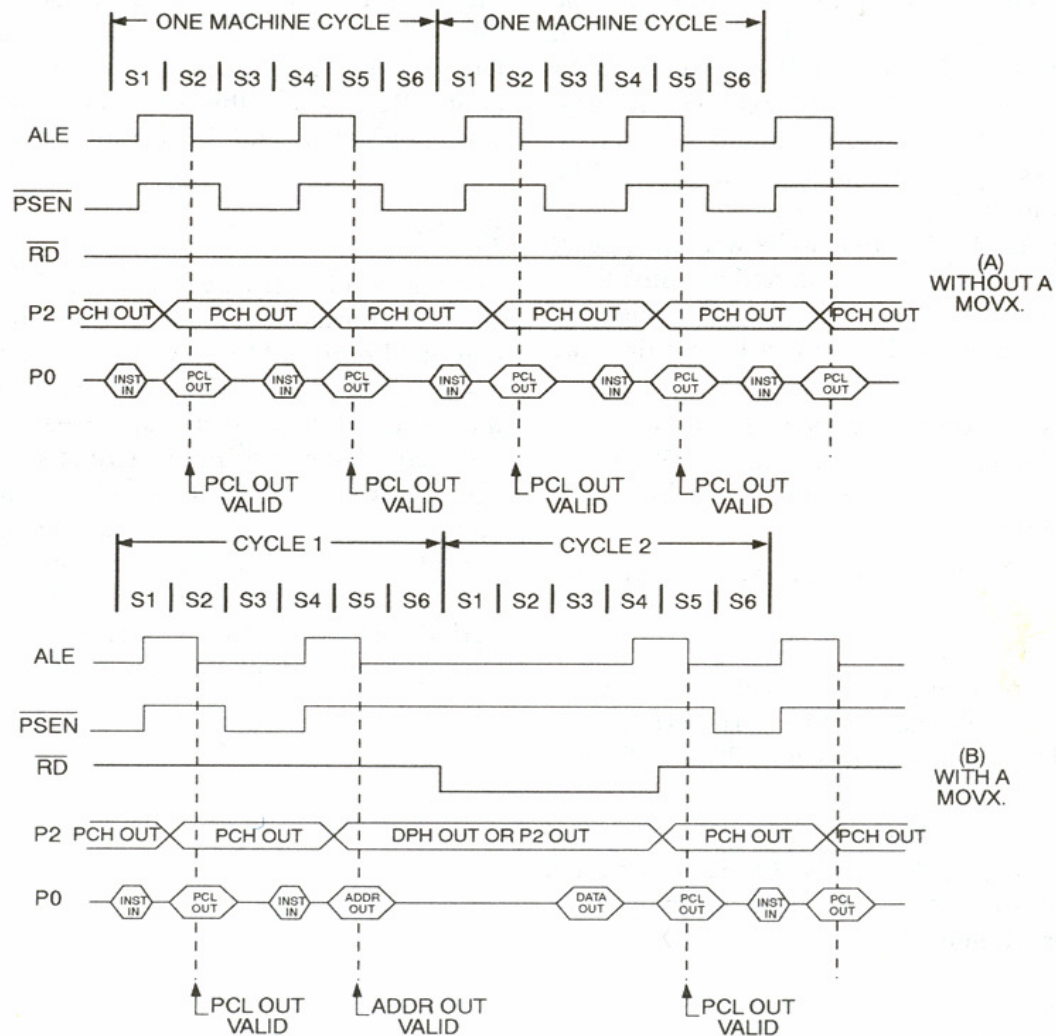

2.7 PSEN

The read strobe for external fetches is $\overline{\text{PSEN}}$. $\overline{\text{PSEN}}$ is not activated for internal fetches. When the CPU is accessing external Program Memory, $\overline{\text{PSEN}}$ is activated twice every cycle (except during a MOVX instruction) whether or not the byte fetched is actually needed for the current instruction. When $\overline{\text{PSEN}}$ is activated its timing is not the same as $\overline{\text{RD}}$. A complete $\overline{\text{RD}}$ cycle, including activation and deactivation of ALE and $\overline{\text{RD}}$, takes 12 oscillator periods. A complete $\overline{\text{PSEN}}$ cycle, including activation and deactivation of ALE and $\overline{\text{PSEN}}$, takes 6 oscillator periods. The execution sequence for these two types of read cycles are shown in Figure 2-8 for comparison.

-
- 2.8 ALE** The main function of ALE is to provide a properly timed signal to latch the low byte of an address from P0 to an external latch during fetches from external Program Memory. For that purpose ALE is activated twice every machine cycle. This activation takes place even when the cycle involves no external fetch. The only time an ALE pulse doesn't come out is during an access to external Data Memory. The first ALE of the second cycle of a MOVX instructions is missing. The ALE disable mode, described in Section 2.8.2, disables the ALE output. Consequently, in any system that does not use external Data Memory, ALE is activated at a constant rate of 1/6 the oscillator frequency, and can be used for external clocking or timing purposes.
- 2.8.1 Overlapping External Program and Data Memory Spaces** In some applications it is desirable to execute a program from the same physical memory that is being used to store data. In the 80C51, the external Program and Data Memory spaces can be combined by ANDing $\overline{\text{PSEN}}$ and $\overline{\text{RD}}$. A positive-logic AND of these two signals produces an active-low read strobe that can be used for the combined physical memory. Since the $\overline{\text{PSEN}}$ cycle is faster than the $\overline{\text{RD}}$ cycle, the external memory needs to be fast enough to accommodate the $\overline{\text{PSEN}}$ cycle.
- 2.8.2 ALE Disable Mode** The ALE signal is used to demultiplex address and data buses on port 0 when used with external program or data memory. Nevertheless, during internal code execution, ALE signal is still generated.
- In order to reduce EMI, ALE signal can be disabled by setting AO bit.
- The AO bit is located in AUXR register at bit location 0 (See Table 2-2). As soon as AO is set, ALE is no longer output but remains active during MOVX and MOVC instructions and external fetches. During ALE disabling, ALE pin is weakly pulled high.

Table 2-2. AUXR Register
Auxillary Register - AUXR (S:8Eh)

7	6	5	4	3	2	1	0
-	-	-	-	-	-	EXTRAM	AO
Bit Number	Bit Mnemonic	Description					
7	-	Reserved The value read from this bit is indeterminate. Do not set this bit.					
6	-	Reserved The value read from this bit is indeterminate. Do not set this bit.					
5	-	Reserved The value read from this bit is indeterminate. Do not set this bit.					
4	-	Reserved The value read from this bit is indeterminate. Do not set this bit.					
3	-	Reserved The value read from this bit is indeterminate. Do not set this bit.					
2	-	Reserved The value read from this bit is indeterminate. Do not set this bit.					
1	EXTRAM	EXTRAM select Clear to map XRAM data in internal XRAM memory. Set to map XRAM data in external XRAM memory.					
0	AO	ALE Output bit Clear to restore ALE operation during internal fetches. Set to disable ALE operation during internal fetches.					

Reset Value = XXXX XX00b

2.9 Timer/Counters

The Atmel 80C51 Microcontrollers implement two general purpose, 16-bit timers/counters. They are identified as Timer 0 and Timer 1, and can be independently configured to operate in a variety of modes as a timer or as an event counter. When operating as a timer, the timer/counter runs for a programmed length of time, then issues an interrupt request. When operating as a counter, the timer/counter counts negative transitions on an external pin. After a preset number of counts, the counter issues an interrupt request.

The various operating modes of each timer/counter are described in the following sections.

2.9.1 Timer/Counter Operations

A basic operation consists of timer registers THx and TLx (x= 0, 1) connected in cascade to form a 16-bit timer. Setting the run control bit (TRx) in TCON register (see Figure 2-3) turns the timer on by allowing the selected input to increment TLx. When TLx overflows it increments THx; when THx overflows it sets the timer overflow flag (TFx) in TCON register. Setting the TRx does not clear the THx and TLx timer registers. Timer registers can be accessed to obtain the current count or to enter preset values. They can be read at any time but TRx bit must be cleared to preset their values, otherwise the behavior of the timer/counter is unpredictable.

The C/Tx# control bit (in TCON register) selects timer operation, or counter operation, by selecting the divided-down peripheral clock or external pin Tx as the source for the counted signal. TRx bit must be cleared when changing the mode of operation, otherwise the behavior of the timer/counter is unpredictable.

For timer operation (C/Tx# = 0), the timer register counts the divided-down peripheral clock. The timer register is incremented once every peripheral cycle (6 peripheral clock periods). The timer clock rate is $F_{PER} / 6$, i.e. $F_{OSC} / 12$ in standard mode or $F_{OSC} / 6$ in X2 mode.

For counter operation (C/Tx# = 1), the timer register counts the negative transitions on the Tx external input pin. The external input is sampled every peripheral cycle. When the sample is high in one cycle and low in the next one, the counter is incremented. Since it takes 2 cycles (12 peripheral clock periods) to recognize a negative transition, the maximum count rate is $F_{PER} / 12$, i.e. $F_{OSC} / 24$ in standard mode or $F_{OSC} / 12$ in X2 mode. There are no restrictions on the duty cycle of the external input signal, but to ensure that a given level is sampled at least once before it changes, it should be held for at least one full peripheral cycle.

In addition to the “timer” or “counter” selection, Timer 0 and Timer 1 have four operating modes from which to select which are selected by bit-pairs (M1, M0) in TMOD. Modes 0, 1, and 2 are the same for both timer/counters. Mode 3 is different. The four operating modes are described below.

Timer 2, has three modes of operation: ‘capture’, ‘auto-reload’ and ‘baud rate generator’.

2.10 Timer 0

Timer 0 functions as either a timer or event counter in four modes of operation. Figure 2-9 to Figure 2-12 show the logical configuration of each mode.

Timer 0 is controlled by the four lower bits of the TMOD register (see Table 2-5) and bits 0, 1, 4 and 5 of the TCON register (see Table 2-3). TMOD register selects the method of timer gating (GATE0), timer or counter operation (T/C0#) and mode of operation (M10 and M00). The TCON register provides timer 0 control functions: overflow flag (TF0), run control bit (TR0), interrupt flag (IE0) and interrupt type control bit (IT0).

For normal timer operation (GATE0= 0), setting TR0 allows TL0 to be incremented by the selected input. Setting GATE0 and TR0 allows external pin INT0# to control timer operation.

Timer 0 overflow (count rolls over from all 1s to all 0s) sets TF0 flag, generating an interrupt request.

It is important to stop timer/counter before changing mode.

2.10.1 Mode 0 (13-bit Timer)

Mode 0 configures timer 0 as a 13-bit timer which is set up as an 8-bit timer (TH0 register) with a modulo 32 prescaler implemented with the lower five bits of the TL0 register (see Figure 2-9). The upper three bits of TL0 register are indeterminate and should be ignored. Prescaler overflow increments the TH0 register.

As the count rolls over from all 1's to all 0's, it sets the timer interrupt flag $\overline{TF0}$. The counted input is enabled to the Timer when $TR0 = 1$ and either $GATE = 0$ or $\overline{INT0} = 1$. (Setting $GATE = 1$ allows the Timer to be controlled by external input $\overline{INT0}$, to facilitate pulse width measurements). TR0 is a control bit in the Special Function register TCON (Table 2-3). GATE is in TMOD.

The 13-bit register consists of all 8 bits of TH0 and the lower 5 bits of TL0. The upper 3 bits of TL0 are indeterminate and should be ignored. Setting the run flag (TR0) does not clear the registers.

Mode 0 operation is the same for Timer 0 as for Timer 1. Substitute TR0, TF0 and $\overline{INT0}$ for the corresponding Timer 1 signals in Table 2-10. There are two different GATE bits, one for Timer 1 (TMOD.7) and one for Timer 0 (TMOD.3).

Figure 2-9. Timer/Counter x (x = 0 or 1) in Mode 0

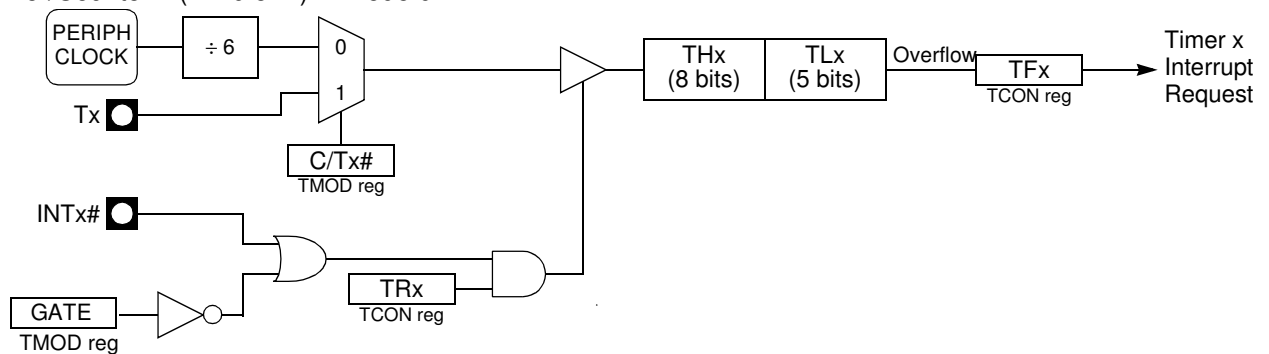

2.10.2 Mode 1 (16-bit Timer)

Mode 1 is the same as Mode 0, except that the Timer register is being run with all 16 bits.

Mode 1 configures timer 0 as a 16-bit timer with the TH0 and TL0 registers connected in cascade (see Figure 2-10). The selected input increments the TL0 register.

Figure 2-10. Timer/Counter x (x = 0 or 1) in Mode 1

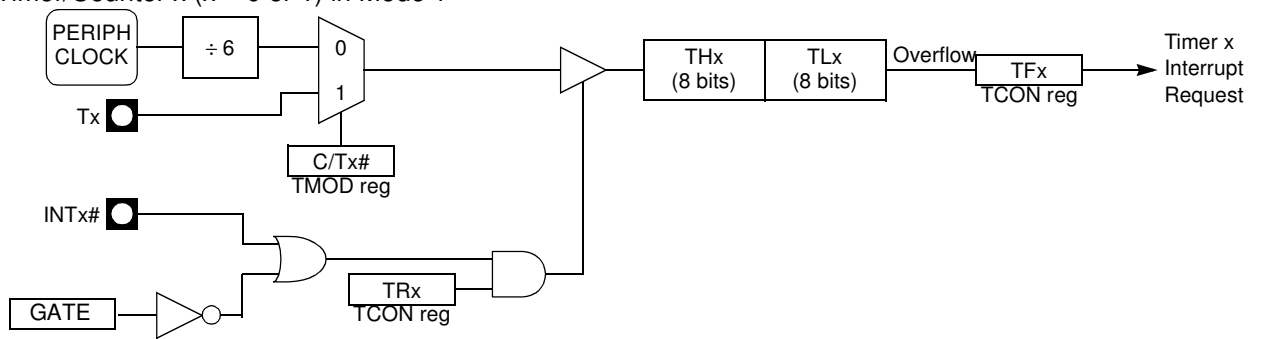

2.10.3 Mode 2 (8-bit Timer with Auto-Reload)

Mode 2 configures timer 0 as an 8-bit timer (TL0 register) that automatically reloads from the TH0 register (see Table 2-5 on page 87). TL0 overflow sets TF0 flag in the TCON register and reloads TL0 with the contents of TH0, which is preset by software. When the interrupt request is serviced, hardware clears TF0. The reload leaves TH0 unchanged. The next reload value may be changed at any time by writing it to the TH0 register.

Mode 2 operation is the same for Timer/Counter 1.

Figure 2-11. Timer/Counter x (x = 0 or 1) in Mode 2

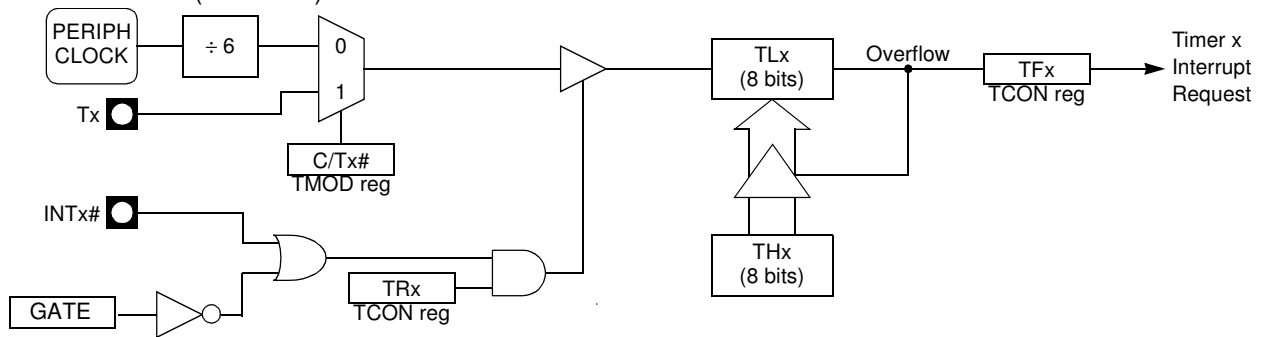

2.10.4 Mode 3 (Two 8-bit Timers)

Mode 3 configures timer 0 so that registers TL0 and TH0 operate as separate 8-bit timers (see Figure 2-12). This mode is provided for applications requiring an additional 8-bit timer or counter. TL0 uses the timer 0 control bits C/T0# and GATE0 in the TMOD register, and TR0 and TF0 in the TCON register in the normal manner. TH0 is locked into a timer function (counting $F_{PER} / 6$) and takes over use of the timer 1 interrupt (TF1) and run control (TR1) bits. Thus, operation of timer 1 is restricted when timer 0 is in mode 3.

Figure 2-12. Timer/Counter 0 in Mode 3: Two 8-bit Counters

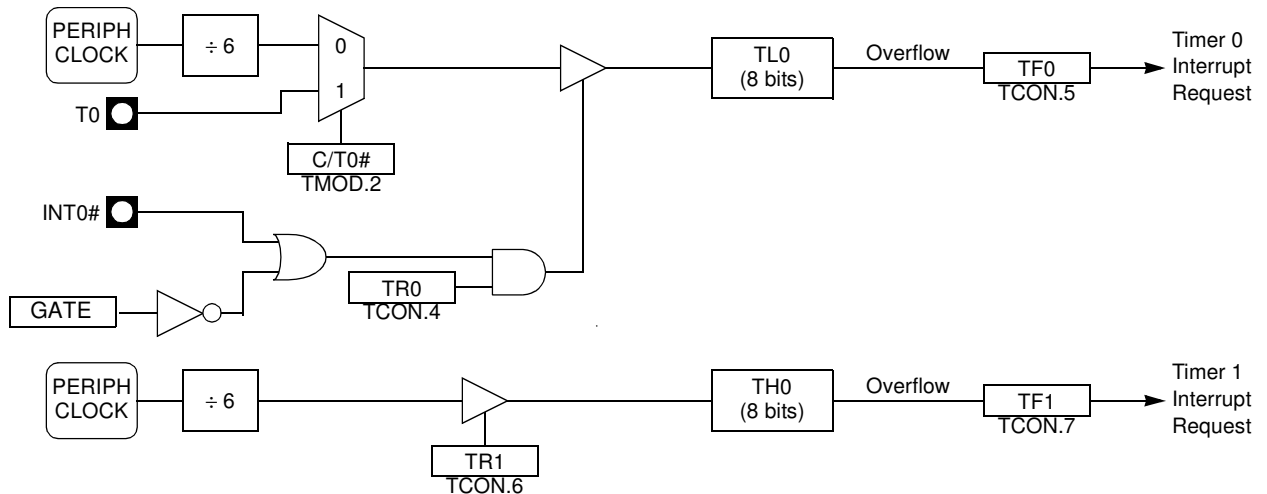

2.11 Timer 1

Timer 1 is identical to timer 0, except for mode 3, which is a hold-count mode. The following comments help to understand the differences:

- Timer 1 functions as either a timer or event counter in three modes of operation. Figure 2-9 to Figure 2-11 show the logical configuration for modes 0, 1, and 2. Timer 1's mode 3 is a hold-count mode.
- Timer 1 is controlled by the four high-order bits of the TMOD register (see Table 2-5 on page 82) and bits 2, 3, 6 and 7 of the TCON register (see Table 2-3 on page 86). The TMOD register selects the method of timer gating (GATE1), timer or counter operation (C/T1#) and mode of operation (M11 and M01). The TCON register provides timer 1 control functions: overflow flag (TF1), run control bit (TR1), interrupt flag (IE1) and interrupt type control bit (IT1).
- Timer 1 can serve as the baud rate generator for the serial port. Mode 2 is best suited for this purpose.
- For normal timer operation (GATE1 = 0), setting TR1 allows TL1 to be incremented by the selected input. Setting GATE1 and TR1 allows external pin INT1# to control timer operation.
- Timer 1 overflow (count rolls over from all 1s to all 0s) sets the TF1 flag generating an interrupt request.
- When timer 0 is in mode 3, it uses timer 1's overflow flag (TF1) and run control bit (TR1). For this situation, use timer 1 only for applications that do not require an interrupt (such as a baud rate generator for the serial port) and switch timer 1 in and out of mode 3 to turn it off and on.
- It is important to stop timer/counter before changing modes.

2.11.1 Mode 0 (13-bit Timer)

Mode 0 configures Timer 1 as a 13-bit timer, which is set up as an 8-bit timer (TH1 register) with a modulo-32 prescaler implemented with the lower 5 bits of the TL1 register (see Figure 2-9). The upper 3 bits of the TL1 register are ignored. Prescaler overflow increments the TH1 register.

Figure 2-13. Timer/Counter 1 Mode 0: 13-bit Counter

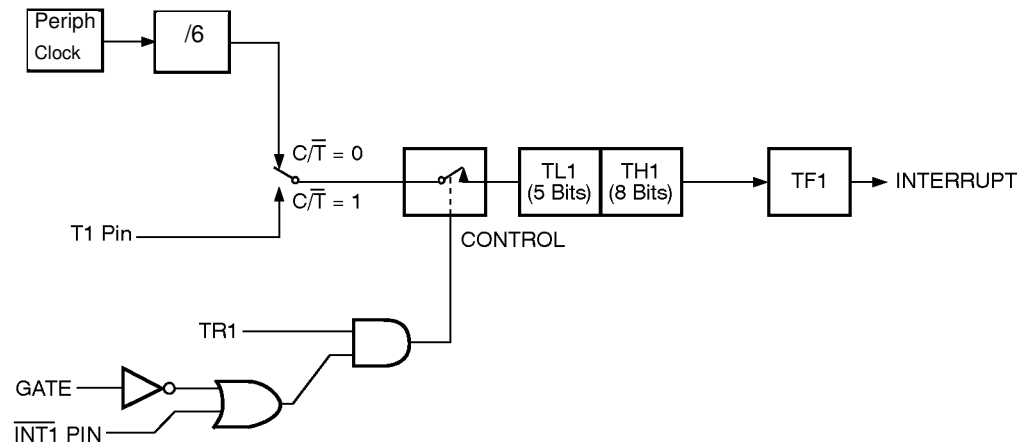

2.11.2 Mode 1 (16-bit Timer)

Mode 1 configures Timer 1 as a 16-bit timer with the TH1 and TL1 registers connected in cascade (see Figure 2-10). The selected input increments the TL1 register.

2.11.3 Mode 2 (8-bit Timer with Auto Reload)

Mode 2 configures Timer 1 as an 8-bit timer (TL1 register) with automatic reload from the TH1 register on overflow (see Figure 2-11). TL1 overflow sets the TF1 flag in the TCON register and reloads TL1 with the contents of TH1, which is preset by software. The reload leaves TH1 unchanged.

Figure 2-14. Timer/Counter 1 Mode 2: 8-bit Auto-reload

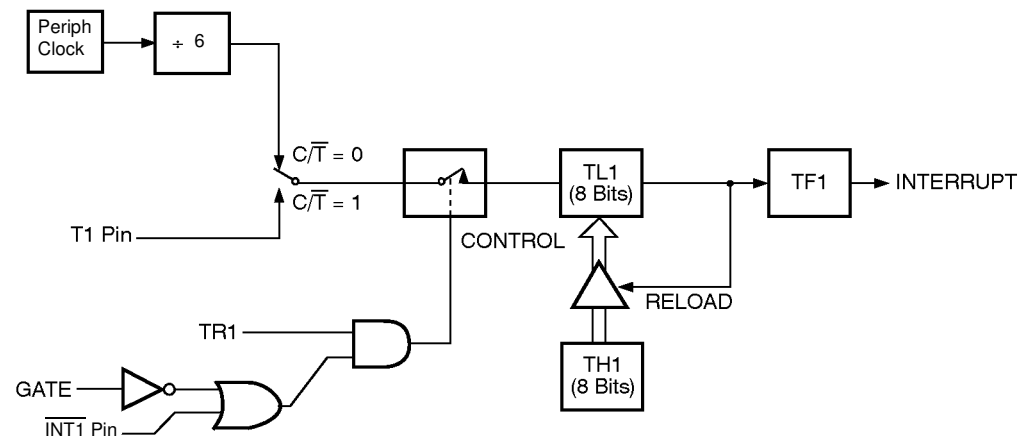

2.11.4 Mode 3 (Halt)

Placing Timer 1 in mode 3 causes it to halt and hold its count. This can be used to halt Timer 1 when TR1 run control bit is not available i.e., when Timer 0 is in mode 3.

2.11.5 Interrupt

Each timer handles one interrupt source; that is the timer overflow flag TF0 or TF1. This flag is set every time an overflow occurs. Flags are cleared when vectoring to the timer interrupt routine. Interrupts are enabled by setting ET_x bit in IE0 register. This assumes interrupts are globally enabled by setting EA bit in the IE0 register.

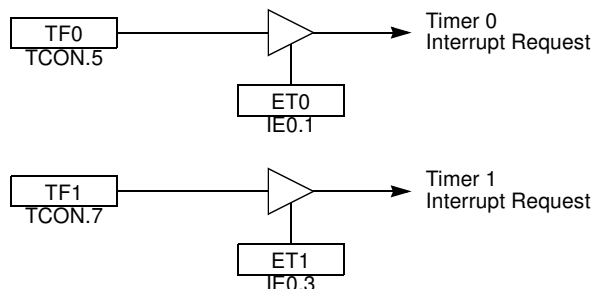
Figure 2-15. Timer Interrupt System

2.11.6 Timer Registers

Table 2-3. TCON Register - TCON (S:88h)
Timer/Counter Control Register.

	7	6	5	4	3	2	1	0
	TF1	TR1	TF0	TR0	IE1	IT1	IE0	IT0
Bit Number	Bit Mnemonic	Description						
7	TF1	Timer 1 Overflow Flag Cleared by hardware when processor vectors to interrupt routine. Set by hardware on timer/counter overflow, when the timer 1 register overflows.						
6	TR1	Timer 1 Run Control Bit Clear to turn off timer/counter 1. Set to turn on timer/counter 1.						
5	TF0	Timer 0 Overflow Flag Cleared by hardware when processor vectors to interrupt routine. Set by hardware on timer/counter overflow, when the timer 0 register overflows.						
4	TR0	Timer 0 Run Control Bit Clear to turn off timer/counter 0. Set to turn on timer/counter 0.						
3	IE1	Interrupt 1 Edge Flag Cleared by hardware when interrupt is processed if edge-triggered (see IT1). Set by hardware when external interrupt is detected on INT1# pin.						
2	IT1	Interrupt 1 Type Control Bit Clear to select low level active (level triggered) for external interrupt 1 (INT1#). Set to select falling edge active (edge triggered) for external interrupt 1.						
1	IE0	Interrupt 0 Edge Flag Cleared by hardware when interrupt is processed if edge-triggered (see IT0). Set by hardware when external interrupt is detected on INT0# pin.						
0	IT0	Interrupt 0 Type Control Bit Clear to select low level active (level triggered) for external interrupt 0 (INT0#). Set to select falling edge active (edge triggered) for external interrupt 0.						

Reset Value = 0000 0000b

Table 2-4. TMOD Register - TMOD (S: 89h)
TMOD - Timer/Counter 0 and 1 Modes

	7	6	5	4	3	2	1	0
	GATE1	C/T1#	M11	M01	GATE0	C/T0#	M10	M00

Bit Number	Bit Mnemonic	Description	
7	GATE1	Timer 1 Gating Control Bit Clear to enable timer 1 whenever the TR1 bit is set. Set to enable timer 1 only while the INT1# pin is high and TR1 bit is set.	
6	C/T1#	Timer 1 Counter/Timer Select Bit Clear for timer operation: timer 1 counts the divided-down system clock. Set for Counter operation: timer 1 counts negative transitions on external pin T1.	
5	M11	Timer 1 Mode Select Bits <u>M11</u> <u>M01</u> <u>Operating mode</u> 0 0 Mode 0: 8-bit timer/counter (TH1) with 5-bit prescaler (TL1). 0 1 Mode 1: 16-bit timer/counter. 1 0 Mode 2: 8-bit auto-reload timer/counter (TL1). Reloaded from TH1 at overflow. 1 1 Mode 3: timer 1 halted. Retains count.	
4	M01		
3	GATE0		Timer 0 Gating Control Bit Clear to enable timer 0 whenever the TR0 bit is set. Set to enable timer/counter 0 only while the INT0# pin is high and the TR0 bit is set.
2	C/T0#		Timer 0 Counter/Timer Select Bit Clear for timer operation: timer 0 counts the divided-down system clock. Set for counter operation: timer 0 counts negative transitions on external pin T0.
1	M10	Timer 0 Mode Select Bit <u>M10</u> <u>M00</u> <u>Operating mode</u> 0 0 Mode 0: 8-bit timer/counter (TH0) with 5-bit prescaler (TL0). 0 1 Mode 1: 16-bit timer/counter. 1 0 Mode 2: 8-bit auto-reload timer/counter (TL0). Reloaded from TH0 at overflow. 1 1 Mode 3: TL0 is an 8-bit timer/counter. TH0 is an 8-bit timer using timer 1's TR0 and TF0 bits.	
0	M00		

Reset Value = 0000 0000b

Table 2-5. TH0 Register - TH0 (S:8Ch)
Timer 0 High Byte Register.

	7	6	5	4	3	2	1	0

Bit Number	Bit Mnemonic	Description
7:0		High Byte of Timer 0.

Reset Value = 0000 0000b

Table 2-6. TL0 Register - *TL0 (S:8Ah)*
Timer 0 Low Byte Register

7	6	5	4	3	2	1	0
Bit Number	Bit Mnemonic	Description					
7:0		Low Byte of Timer 0.					

Reset Value = 0000 0000b

Table 2-7. TH1 Register - *TH1 (S:8Dh)*
Timer 1 High Byte Register

7	6	5	4	3	2	1	0
Bit Number	Bit Mnemonic	Description					
7:0		High Byte of Timer 1.					

Reset Value = 0000 0000b

Table 2-8. TL1 Register - *TL1 (S:8Bh)*
Timer 1 Low Byte Register

7	6	5	4	3	2	1	0
Bit Number	Bit Mnemonic	Description					
7:0		Low Byte of Timer 1.					

Reset Value = 0000 0000b

When Timer 0 is in Mode 3, Timer 1 can be turned on and off by switching it out of and into its own Mode 3, or can still be used by the serial port as a baud rate generator, or in fact, in any application not requiring an interrupt.

2.12 Timer 2

Timer 2 is a 16-bit timer/counter which is present in most of the Atmel 8051 microcontrollers. The count is maintained by two 8-bit timer registers, TH2 and TL2, that are cascade connected. Like Timers 0 and 1, it can operate either as a timer or as an event counter.

It is controlled by the T2CON register (See Table 2-9) and the T2MOD register (See Table 2-10). Timer 2 operation is similar to Timer 0 and Timer 1. $C/\overline{T2}$ selects $F_{OSC}/6$ (timer operation) or external pin T2 (counter operation) as timer register input. Setting TR2 allows TL2 to be incremented by the selected input.

It has three operating modes: 'capture', 'autoload' and 'baud rate generator', which are selected by bits in T2CON as shown in Table 2-10.

RCLK + TCLK	$CP/\overline{RL2}$	TR2	Mode
0	0	1	16-bit auto-reload
0	1	1	16-bit capture
1	X	1	baud rate generator
X	X	0	(off)

In the capture mode there are two options which are selected by bit EXEN2 in T2CON. If EXEN2 = 0, then Timer 2 is a 16-bit timer or counter which upon overflowing sets bit TF2, the Timer 2 overflow bit, which can be used to generate an interrupt. If EXEN2 = 1, then Timer 2 still does the above, but with the added feature that a 1-to-0 transition at external input T2EX causes the current value in the Timer 2 registers, TL2 and TH2, to be captured into registers RCAP2L and RCAP2H, respectively. RCAP2L and RCAP2H are new Special Function Registers in the 80C52, 83C154 and 83C154D. In addition, the transition at T2EX causes bit EXF2 in T2CON to be set, and EXF2, like TF2, can generate an interrupt.

The capture mode is illustrated in Figure 2-16.

Figure 2-16. Timer 2 in Capture Mode

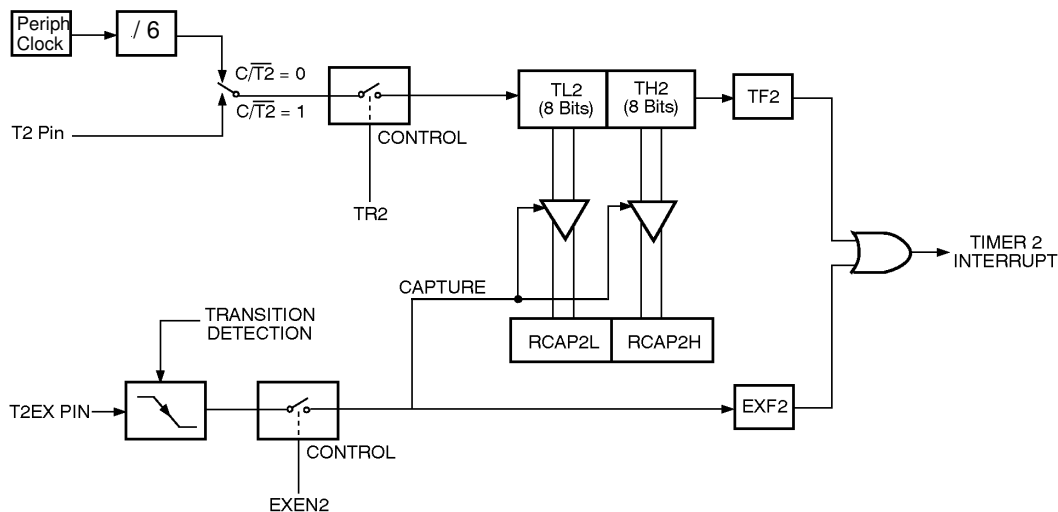

In the auto-reload mode there are again two options, which are selected by bit EXEN2 in T2CON. If EXEN2 = 0, then when Timer 2 rolls over it not only sets TF2 but also causes the Timer 2 registers to be reloaded with the 16-bit value in registers RCAP2L and RCAP2H, which are preset by software. If EXEN2 = 1, then Timer 2 still does the above,

but with the added feature that a 1-to-0 transition at external input T2EX will also trigger the 16-bit reload and set EXF2.

2.12.1 Auto-reload Mode

The auto-reload mode configures timer 2 as a 16-bit timer or event counter with automatic reload. This feature is controlled by the DCEN bit in the T2MOD register (See Table 2-10). Setting the DCEN bit enables timer 2 to count up or down as shown in Figure 2-17. In this mode the T2EX pin controls the counting direction.

When T2EX is high, timer 2 up-counts. Timer overflow occurs at FFFFh which sets the TF2 flag and generates an interrupt request. The overflow also causes the 16-bit value in the RCAP2H and RCAP2L registers to be loaded into the timer registers TH2 and TL2.

When T2EX is low, timer 2 down-counts. Timer underflow occurs when the count in the timer registers, TH2 and TL2, equals the value stored in the RCAP2H and RCAP2L registers. The underflow sets TF2 flag and reloads FFFFh into the timer registers.

The EXF2 bit toggles when timer 2 overflow or underflow occurs, depending on the direction of the count. EXF2 does not generate an interrupt. This bit can be used to provide 17-bit resolution.

Figure 2-17. Auto-reload Mode Up/Down Counter

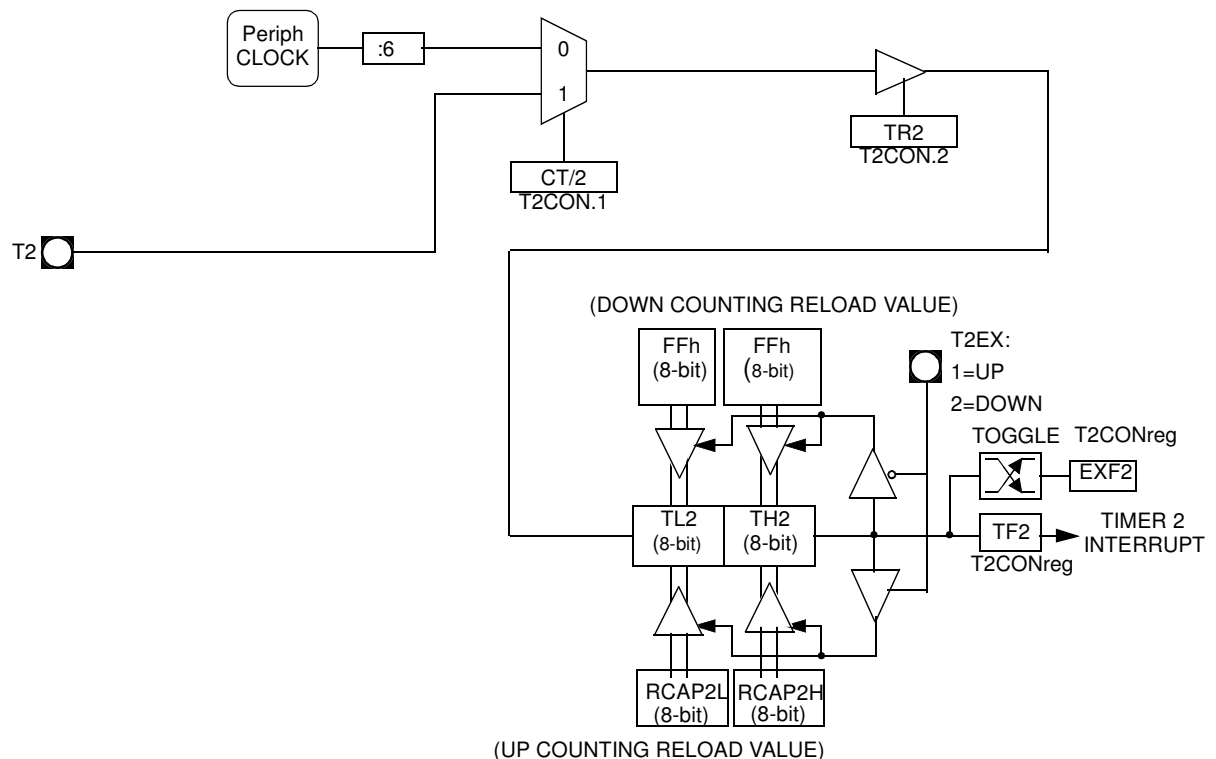

2.12.2 Programmable Clock-output

In clock-out mode, timer 2 operates as a 50% duty-cycle, programmable clock generator (See Figure 2-18). The input clock increments TL2 at frequency $F_{OSC}/2$. The timer repeatedly counts to overflow from a loaded value. At overflow, the contents of the RCAP2H and RCAP2L registers are loaded into TH2 and TL2. In this mode, timer 2 overflows do not generate interrupts. The formula gives the clock-out frequency,

depending on the system oscillator frequency and the value in the RCAP2H and RCAP2L registers:

$$\text{Clock - OutFrequency} = \frac{F_{osc} \times 2^{x2}}{2 \times (65536 - RCAP2H/RCAP2L)}$$

Note: X2 bit is located in the CKCON register.
 In X2 mode, $F_{OSC}=F_{XTAL}$. In standard mode, $F_{OSC}=F_{XTAL}/2$.

For a 16 MHz system clock, timer 2 has a programmable frequency range of 61 Hz ($F_{OSC}/2^{16}$) to 4 MHz ($F_{OSC}/4$). The generated clock signal is brought out to the T2 pin (P1.0).

Timer 2 is programmed for the clock-out mode as follows:

- Set T2OE bit in the T2MOD register.
- Clear C/T2 bit in the T2CON register.
- Determine the 16-bit reload value from the formula and enter it in the RCAP2H/RCAP2L registers.
- Enter a 16-bit initial value in timer registers TH2/TL2. It can be the same as the reload value, or different, depending on the application.
- To start the timer, set TR2 run control bit in the T2CON register.

It is possible to use timer 2 as a baud rate generator and a clock generator simultaneously. For this configuration, the baud rates and clock frequencies are not independent since both functions use the values in the RCAP2H and RCAP2L registers.

Figure 2-18. Clock-out Mode

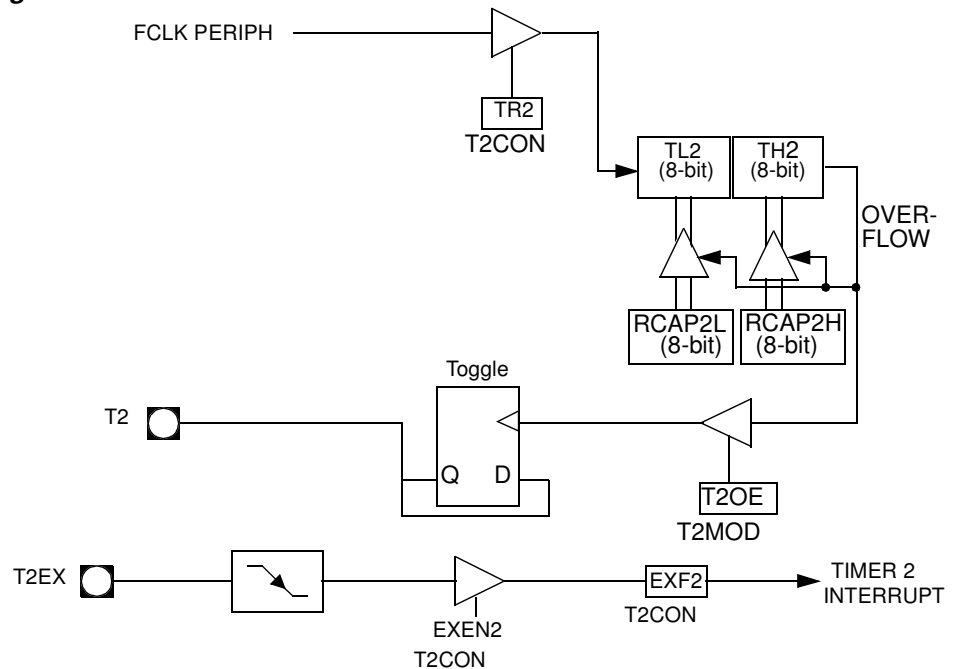

2.12.3 Timer Registers

Table 2-9. T2CON Register - T2CON (S:C8h)
Timer 2 Control Register

7	6	5	4	3	2	1	0
TF2	EXF2	RCLK	TCLK	EXEN2	TR2	C/T2#	CP/RL2#
Bit Number	Bit Mnemonic	Description					
7	TF2	Timer 2 overflow Flag TF2 is not set if RCLK=1 or TCLK = 1. Must be cleared by software. Set by hardware on timer 2 overflow.					
6	EXF2	Timer 2 External Flag Set when a capture or a reload is caused by a negative transition on T2EX pin if EXEN2=1. Set to cause the CPU to vector to timer 2 interrupt routine when timer 2 interrupt is enabled. Must be cleared by software.					
5	RCLK	Receive Clock bit Clear to use timer 1 overflow as receive clock for serial port in mode 1 or 3. Set to use timer 2 overflow as receive clock for serial port in mode 1 or 3.					
4	TCLK	Transmit Clock bit Clear to use timer 1 overflow as transmit clock for serial port in mode 1 or 3. Set to use timer 2 overflow as transmit clock for serial port in mode 1 or 3.					
3	EXEN2	Timer 2 External Enable bit Clear to ignore events on T2EX pin for timer 2 operation. Set to cause a capture or reload when a negative transition on T2EX pin is detected, if timer 2 is not used to clock the serial port.					
2	TR2	Timer 2 Run control bit Clear to turn off timer 2. Set to turn on timer 2.					
1	C/T2#	Timer/Counter 2 select bit Clear for timer operation (input from internal clock system: F _{OSC}). Set for counter operation (input from T2 input pin).					
0	CP/RL2#	Timer 2 Capture/Reload bit If RCLK=1 or TCLK=1, CP/RL2# is ignored and timer is forced to auto-reload on timer 2 overflow. Clear to auto-reload on timer 2 overflows or negative transitions on T2EX pin if EXEN2=1. Set to capture on negative transitions on T2EX pin if EXEN2=1.					

Reset Value = 0000 0000b

Bit addressable

Table 2-10. T2MOD Register - *T2MOD (S:C9h)*
Timer 2 Mode Control Register

7	6	5	4	3	2	1	0
-	-	-	-	-	-	T2OE	DCEN
Bit Number	Bit Mnemonic	Description					
7	-	Reserved The value read from this bit is indeterminate. Do not set this bit.					
6	-	Reserved The value read from this bit is indeterminate. Do not set this bit.					
5	-	Reserved The value read from this bit is indeterminate. Do not set this bit.					
4	-	Reserved The value read from this bit is indeterminate. Do not set this bit.					
3	-	Reserved The value read from this bit is indeterminate. Do not set this bit.					
2	-	Reserved The value read from this bit is indeterminate. Do not set this bit.					
1	T2OE	Timer 2 Output Enable bit Clear to program P1.0/T2 as clock input or I/O port. Set to program P1.0/T2 as clock output.					
0	DCEN	Down Counter Enable bit Clear to disable timer 2 as up/down counter. Set to enable timer 2 as up/down counter.					

Reset Value = XXXX XX00b

Not bit addressable

Table 2-11. TH2 Register - *TH2 (S:CDh)*
Timer 2 High Byte Register

7	6	5	4	3	2	1	0
-	-	-	-	-	-	-	-
Bit Number	Bit Mnemonic	Description					
7:0		High Byte of Timer 2.					

Reset Value = 0000 0000b

Not bit addressable

Table 2-12. TL2 Register - *TL2 (S:CCh)*
Timer 2 Low Byte Register

7	6	5	4	3	2	1	0
-	-	-	-	-	-	-	-
Bit Number	Bit Mnemonic	Description					
7:0		Low Byte of Timer 2.					

Reset Value = 0000 0000b
Not bit addressable

Table 2-13. RCAP2H Register - *RCAP2H (S:CBh)*
Timer 2 Reload/Capture High Byte Register

7	6	5	4	3	2	1	0
-	-	-	-	-	-	-	-
Bit Number	Bit Mnemonic	Description					
7:0		High Byte of Timer 2 Reload/Capture.					

Reset Value = 0000 0000b
Not bit addressable

Table 2-14. RCAP2L Register - *RCAP2L (S:CAh)*
Timer 2 Reload/Capture Low Byte Register

7	6	5	4	3	2	1	0
-	-	-	-	-	-	-	-
Bit Number	Bit Mnemonic	Description					
7:0		Low Byte of Timer 2 Reload/Capture.					

Reset Value = 0000 0000b
Not bit addressable

2.13 Serial Interface

It provides both synchronous and asynchronous communication modes. It operates as a Universal Asynchronous Receiver and Transmitter (UART) in three full-duplex modes (Modes 1, 2 and 3). Asynchronous transmission and reception can occur simultaneously and at different baud rates.

It is also receive-buffered, meaning it can commence reception of a second byte before a previously received byte has been read from the receive register. (However, if the first byte still hasn't been read by the time reception of the second byte is complete, one of the bytes will be lost). The serial port receive and transmit registers are both accessed at Special Function Register SBUF. Writing to SBUF loads the transmit register, and reading SBUF accesses a physically second receive register.

The serial port can operate in 4 modes:

Mode 0: Serial data enters and exits through RXD. TXD outputs the shift clock. 8 bits are transmitted/received: 8 data bits (LSB first). The baud rate is fixed at 1/12 the oscillator frequency.

Mode 1: 10 bits are transmitted (through TXD) or received (through RXD): a start bit (0), 8 data bits (LSB first), and a stop bit (1). On receive, the stop bit goes into RB8 in Special Function Register SCON. The baud rate is variable.

Mode 2: 11 bits are transmitted (through TXD) or received (through RXD): a start bit (0), 8 data bits (LSB first), a programmable 9th data bit, and a stop bit (1). On transmit, the 9th data bit (TB8 in SCON) can be assigned the value of 0 or 1. Or, for example, the parity bit (P, in the PSW) could be moved into TB8. On receive, the 9th data bit goes into RB8 in Special Function register SCON, while the stop bit is ignored. The baud rate is programmable to either 1/32 or 1/64 the oscillator frequency.

Mode 3: 11 bits are transmitted (through TXD) or received (through RXD): a start bit (0), 8 data bits (LSB first), a programmable 9th data bit and a stop bit (1). In fact, Mode 3 is the same as Mode 2 in all respects except the baud rate. The baud rate in Mode 3 is variable.

In all four modes, transmission is initiated in Mode 0 by the condition RI = 0 and REN = 1. Reception is initiated in Mode 0 by the condition RI = 0 and REN = 1. Reception is initiated in the other modes by the incoming start bit if REN = 1.

Serial I/O port includes the following enhancements:

- Framing error detection
- Automatic address recognition

The serial port control and status register is the Special Function Register SCON, shown in Table 2-17. This register contains not only the mode selection bits, but also the 9th data bit for transmit and receive (TB8 and RB8), and the serial port interrupts bits (TI and RI).

7	6	5	4	3	2	1	0
FE/SM0	SM1	SM2	REN	TB8	RB8	TI	RI
Bit Number	Bit Mnemonic	Description					
7	FE	Framing Error bit (SMOD0=1) Clear to reset the error state, not cleared by a valid stop bit. Set by hardware when an invalid stop bit is detected. SMOD0 must be set to enable access to the FE bit					
	SM0	Serial port Mode bit 0 Refer to SM1 for serial port mode selection. SMOD0 must be cleared to enable access to the SM0 bit					
6	SM1	Serial port Mode bit 1					
		<u>SM0</u>	<u>SM1</u>	<u>Mode</u>	<u>Description</u>	<u>Baud Rate</u>	
		0	0	0	Shift Register	$F_{CPU PERIPH}/6$	
		0	1	1	8-bit UART	Variable	
		1	0	2	9-bit UART	$F_{CPU PERIPH}/32$ or $/16$	
1	1	3	39-bit UART	Variable			
5	SM2	Serial port Mode 2 bit / Multiprocessor Communication Enable bit Clear to disable multiprocessor communication feature. Set to enable multiprocessor communication feature in mode 2 and 3, and eventually mode 1. This bit should be cleared in mode 0.					
4	REN	Reception Enable bit Clear to disable serial reception. Set to enable serial reception.					
3	TB8	Transmitter Bit 8 / Ninth bit to transmit in modes 2 and 3 o transmit a logic 0 in the 9th bit. Set to transmit a logic 1 in the 9th bit.					
2	RB8	Receiver Bit 8 / Ninth bit received in modes 2 and 3 Cleared by hardware if 9th bit received is a logic 0. Set by hardware if 9th bit received is a logic 1. In mode 1, if SM2 = 0, RB8 is the received stop bit. In mode 0 RB8 is not used.					
1	TI	Transmit Interrupt flag Clear to acknowledge interrupt. Set by hardware at the end of the 8th bit time in mode 0 or at the beginning of the stop bit in the other modes.					
0	RI	Receive Interrupt flag Clear to acknowledge interrupt. Set by hardware at the end of the 8th bit time in mode 0, see Figure 2-26. and Figure 2-27. in the other modes.					

Reset Value = 0000 0000b

Bit addressable

2.13.1 Baud Rates

The baud rate in Mode 0 is fixed:

The baud rate in Mode 2 depends on the value of bit SMOD in Special Function Register PCON.

If SMOD = 0 (which is its value on reset), the baud rate is 1/64 the oscillator frequency. If SMOD = 1, the baud rate is 1/32 the oscillator frequency.

In the 80C51, the baud rates in Modes 1 and 3 are determined by the Timer 1 overflow rate. In case of Timer2, these baud rates can be determined by Timer 1, or by Timer 2, or by both (one for transmit and the other for receive).

Baud Rate Selection for UART for Mode 1 and 3

The Baud Rate Generator for transmit and receive clocks can be selected separately via the T2CON and BDRCON registers.

Figure 2-19. Baud Rate Selection

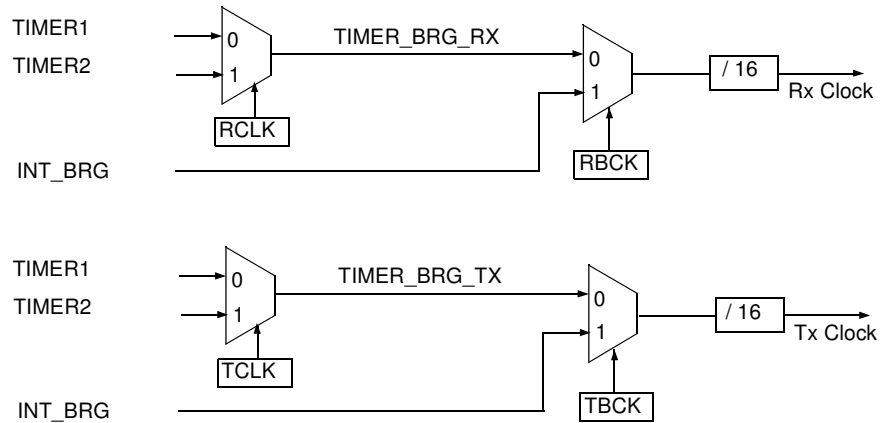

2.13.2 Baud Rate Selection Table for UART

TCLK (T2CON)	RCLK (T2CON)	TBCK (BDRCON)	RBCK (BDRCON)	Clock Source UART Tx	Clock Source UART Rx
0	0	0	0	Timer 1	Timer 1
1	0	0	0	Timer 2	Timer 1
0	1	0	0	Timer 1	Timer 2
1	1	0	0	Timer 2	Timer 2
X	0	1	0	INT_BRG	Timer 1
X	1	1	0	INT_BRG	Timer 2
0	X	0	1	Timer 1	INT_BRG
1	X	0	1	Timer 2	INT_BRG
X	X	1	1	INT_BRG	INT_BRG

2.13.3 Internal Baud Rate Generator (BRG)

When the internal Baud Rate Generator is used, the Baud Rates are determined by the BRG overflow depending on the BRL reload value, the value of SPD bit (Speed Mode) in BDRCON register and the value of the SMOD1 bit in PCON register.

Figure 2-20. Internal Baud Rate

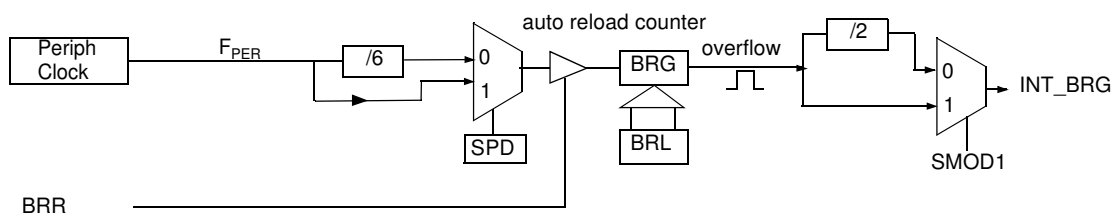

- The baud rate for UART is taken by formula:

$$\text{Baud_Rate} = \frac{2^{\text{SMOD1}} \times F_{\text{PER}}}{6^{(1-\text{SPD})} \times 32 \times [256 - (\text{BRL})]}$$

$$(\text{BRL}) = 256 - \frac{2^{\text{SMOD1}} \times F_{\text{PER}}}{6^{(1-\text{SPD})} \times 32 \times \text{Baud_Rate}}$$

Table 2-15. Example of computed value when X2=1, SMOD1=1, SPD=1
Example of computed value when X2=1, SMOD1=1, SPD=1

Baud Rates	F _{OSCA} = 16.384 MHz		F _{OSCA} = 24 MHz	
	BRL	Error (%)	BRL	Error (%)
115200	247	1.23	243	0.16
57600	238	1.23	230	0.16
38400	229	1.23	217	0.16
28800	220	1.23	204	0.16
19200	203	0.63	178	0.16
9600	149	0.31	100	0.16
4800	43	1.23	-	-

Table 2-16. Example of computed value when X2=0, SMOD1=0, SPD=0
Example of computed value when X2=0, SMOD1=0, SPD=0

Baud Rates	F _{OSCA} = 16.384 MHz		F _{OSCA} = 24 MHz	
	BRL	Error (%)	BRL	Error (%)
4800	247	1.23	243	0.16
2400	238	1.23	230	0.16
1200	220	1.23	204	0.16
600	185	0.16	152	0.16

The baud rate generator can be used for mode 1 or 3 (refer to Figure 2-22 on page 100), but also for mode 0 for UART, thanks to the bit SRC located in BDRCON register (Table 2-29.)

2.13.4 Using Timer 1 to Generate Baud Rates

When Timer 1 is used as the baud rate generator, the baud rates in Modes 1 and 3 are determined by the Timer 1 overflow rate and the value of SMOD as follows:

The Timer 1 interrupt should be disabled in this application. The Timer itself can be configured for either “timer” or “counter” operation, and in any of its 3 running modes. In the most typical applications, it is configured for “timer” operation, in the auto-reload mode (high nibble of TMOD = 0010B). In that case, the baud rate is given by the formula

One can achieve very low baud rates with Timer 1 by leaving the Timer 1 interrupt enabled, and configuring the Timer to run as a 16-bit timer (high nibble of TMOD = 0001B), and using the Timer 1 interrupt to do a 16-bit software reload.

Figure 2-21 lists various commonly used baud rates and how they can be obtained from Timer 1.

Figure 2-21. Timer 1 Generated Commonly Used Baud Rates

Fosc (MHz)	11.0592	12	14.7456	16	20	SMOD
Baudrate						
150	40h	30h	00h			0
300	A0h	98h	80h	75h	52h	0
600	D0h	CCh	C0h	BBh	A9h	0
1200	E8h	E6h	E0h	DEh	D5h	0
2400	F4h	F3h	F0h	EFh	EAh	0
4800		F3h	EFh	EFh		1
4800	FAh		F8h		F5h	0
9600	FDh		FCh			0
9600					F5h	1
19200	FDh		FCh			1
38400			FEh			
76800			FFh			

2.13.5 Using Timer 2 to Generate Baud Rates

Timer 2 is selected as the baud rate generator by setting $TCLK$ and/or $RCLK$ in $T2CON$ (Table 2-9). Note then the baud rates for transmit and receive can be simultaneously different. Setting $RCLK$ and/or $TCLK$ puts Timer 2 into its baud rate generator mode, as shown in Figure 2-22.

Figure 2-22. Timer 2 in Baud Rate Generator Mode.

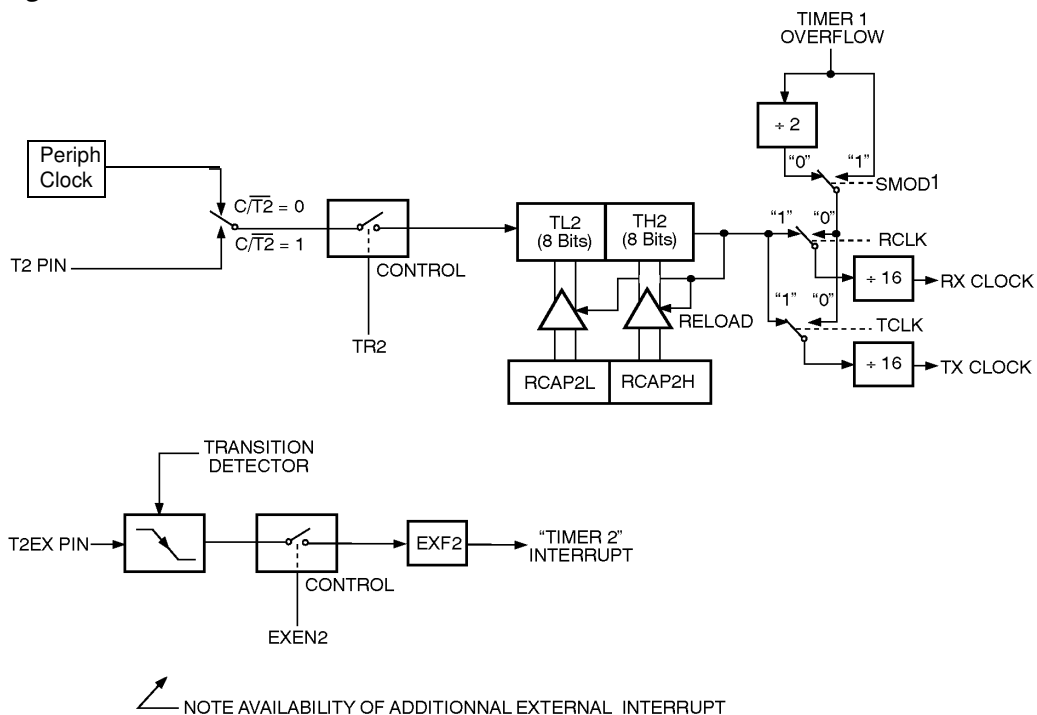

The baud rate generator mode is similar to the auto-reload mode, in that a rollover in $TH2$ causes the Timer 2 registers to be reloaded with the 16-bit value in registers $RCAP2H$ and $RCAP2L$, which are preset by software.

Now, the baud rates in Modes 1 and 3 are determined by Timer 2's overflow rate as follows:

The Timer can be configured for either "timer" or "counter" operation. In the most typical applications, it is configured for "timer" operation ($C/T2 = 0$). "Timer" operation is a little different for Timer 2 when it's being used as a baud rate generator. Separately as a timer it would increment every machine cycle (thus at $1/12$ the oscillator frequency). As a baud rate generator, however, it increments every state time (thus at $1/2$ the oscillator frequency).

Timer 2 as a baud rate generator is shown in Figure 2-22. This Figure is valid only if $RCLK + TCLK = 1$ in $T2CON$. Note that a rollover in $TH2$ does not set $TF2$, and will not generate an interrupt. Therefore, the Timer 2 interrupt does not have to be disabled when Timer 2 is in the baud rate generator mode. Note too, that if $EXEN2$ is set, a 1-to-0 transition in $T2EX$ will set $EXF2$ but will not cause a reload from ($RCAP2H$, $RCAP2L$) to ($TH2$, $TL2$). Thus when Timer 2 is in use as a baud rate generator, $T2EX$ can be used as an extra external interrupt, if desired.

It should be noted that when Timer 2 is running ($TR2 = 1$) in "Timer" function in the baud rate generator mode, one should not try to read or write $TH2$ or $TL2$. Under these conditions the Timer is being incremented every state time, and the results of a read or write may not be accurate. The $RCAP$ registers may be read, but shouldn't be written to, because a write might overlap a reload and cause write and/or reload errors. In this case, turn the Timer off (clear $TR2$) before accessing the Timer 2 or $RCAP$ registers.

Figure 2-23. Timer 2 Generated Commonly Used Baud Rates

Fosc (MHz)	6	11.0592	12	16
Baudrate (RCAP2H - RACP2L)				
110	F9-57			EE-3F
300	FD-8F	FB-80	FB-1E	F9-7D
600	FE-C8	FD-C0	FD-8F	FC-BF
1200	FF-64	FE-E0	FE-C8	FE-5F
2400	FF-B2	FF-70	FF-64	FF-30
4800	FF-D9	FF-B8	FF-B2	FF-98
9600		FF-DC	FF-D9	FF-CC
19200		FF-EE		FF-E6
38400		FF-F7		FF-F3
56800		FF-FA		

XX-XX are values of RCAP2H-RCAP2L

2.13.6 More About Mode 0

Serial data enters and exits through RXD. TXD outputs the shift clock. 8 bits are transmitted/received: 8 data bits (LSB first). The baud rate is fixed at 1/12 the oscillator frequency.

Figure 2-24 shows a simplified functional diagram of the serial port in mode 0, and associated timing.

Transmission is initiated by any instruction that uses SBUF as a destination register. The “write to SBUF” signal at S6P2 also loads a 1 into the 9th bit position of the transmit shift register and tells the TX Control block to commence a transmission. The internal timing is such that one full machine cycle will elapse between “write to SBUF”, and activation of SEND.

SEND enables the output of the shift register to the alternate output function line of P3.0, and also enables SHIFT CLOCK to the alternate output function line of P3.1. SHIFT CLOCK is low during S3, S4, and S5 of every machine cycle, and high during S6, S1 and S2. At S6P2 of every machine cycle in which SEND is active, the contents of the transmit shift register are shifted to the right one position.

As data bits shift out to the right, zeros come in from the left. When the MSB of the data byte is at the output position of the shift register, then the 1 that was initially loaded into the 9th position, is just to the left of the MSB, and all positions to the left of that contain zeros. This condition flags the TX Control block to do one last shift and then deactivate SEND and set T1. Both of these actions occur at S1P1 of the 10th machine cycle after “write to SBUF.”

Reception is initiated by the condition REN = 1 and RI = 0. At S6P2 of the next machine cycle, the RX Control unit writes the bits 11111110 to the receive shift register, and in the next clock phase activates RECEIVE.

RECEIVE enables SHIFT CLOCK to the alternate output function line of P3.1. Shift CLOCK makes transitions at S3P1 and S6P1 of every machine cycle. At S6P2 of every cycle in which RECEIVE is active, the contents of the receive shift register are shifted to the left one position. The value that comes in from the right is the value that was sampled at the P3.0 pin at S5P2 of the same machine cycle.



As data bits come in from the right, 1's shift out to the left. When the 0 that was initially loaded into the rightmost position arrives at the leftmost position in the shift and load SBUF. At S1P1 of the 10th machine cycle after the write to SCON that cleared RI, RECEIVE is cleared and RI is set.

2.13.7 More About Mode 1

Ten bits are transmitted (through TXD), or received (through RXD): a start bit (0), 8 data bits (LSB first), and a stop bit (1). On receive, the stop bit goes into RB8 in SCON. In the 80C51 the baud rate is determined by the Timer 1 overflow rate. In the microcontroller having Timer 2 feature, it is determined either by the Timer 1 overflow rate, or the Timer 2 overflow rate, or both (one for transmit and the other for receive).

Figure 2-25 shows a simplified functional diagram of the serial port in Mode 1, and associated timings for transmit and receive.

Transmission is initiated by any instruction that uses SBUF as a destination register. The "write to SBUF" signal also loads a 1 into the 9th bit position of the transmit shift register and flags the TX Control unit that a transmission is requested. Transmission actually commences at S1P1 of the machine cycle following the next rollover in the divide-by-16 counter. (Thus, the bit times are synchronized to the divide-by-16 counter, not to the "write to SBUF" signal).

The transmission begins with activation of $\overline{\text{SEND}}$, which puts the start bit at TXD. One bit time later, DATA is activated, which enables the output bit of the transmit shift register to TXD. The first shift pulse occurs one bit time after that.

As data bits shift out to the right, zeros are clocked in from the left. When the MSB of the data byte is at the output position of the shift register, then the 1 that was initially loaded into the 9th position is just to the left of the MSB, and all positions to the left of that contain zeroes. This condition flags the TX Control unit to do one last shift and then deactivate $\overline{\text{SEND}}$ and set TI. This occurs at the 10th divide-by-16 rollover after "write to SBUF".

Reception is initiated by a detected 1-to-0 transition at RXD. For this purpose RXD is sampled at a rate of 16 times whatever baud rate has been established. When a transition is detected, the divide-by-16 counter is immediately reset, and 1FFH is written into the input shift register. Resetting the divide-by-16 counter aligns its rollovers with the boundaries of the incoming bit times.

Figure 2-24. Serial Port Mode 0

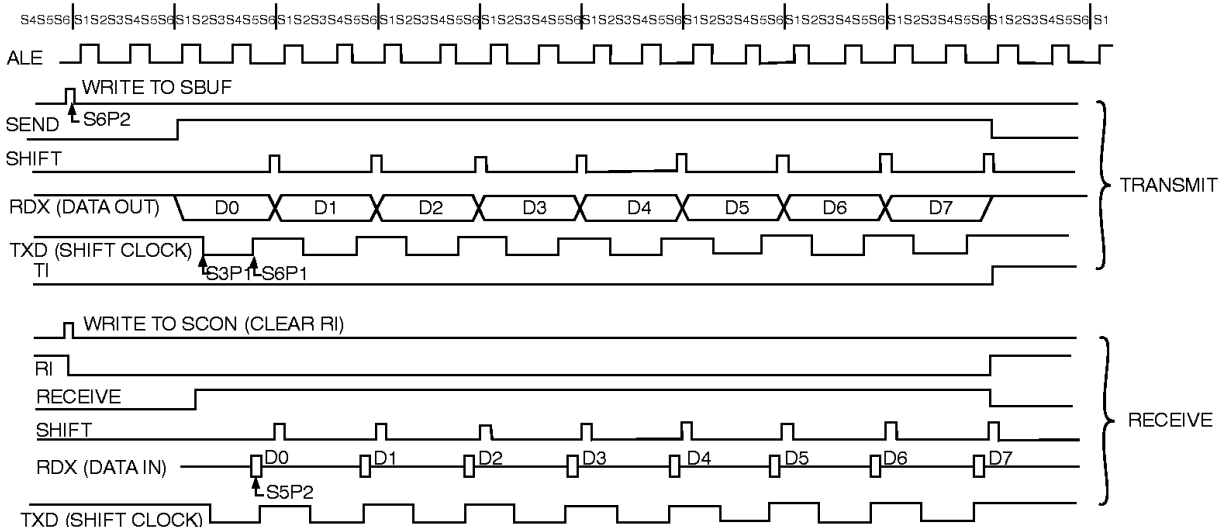
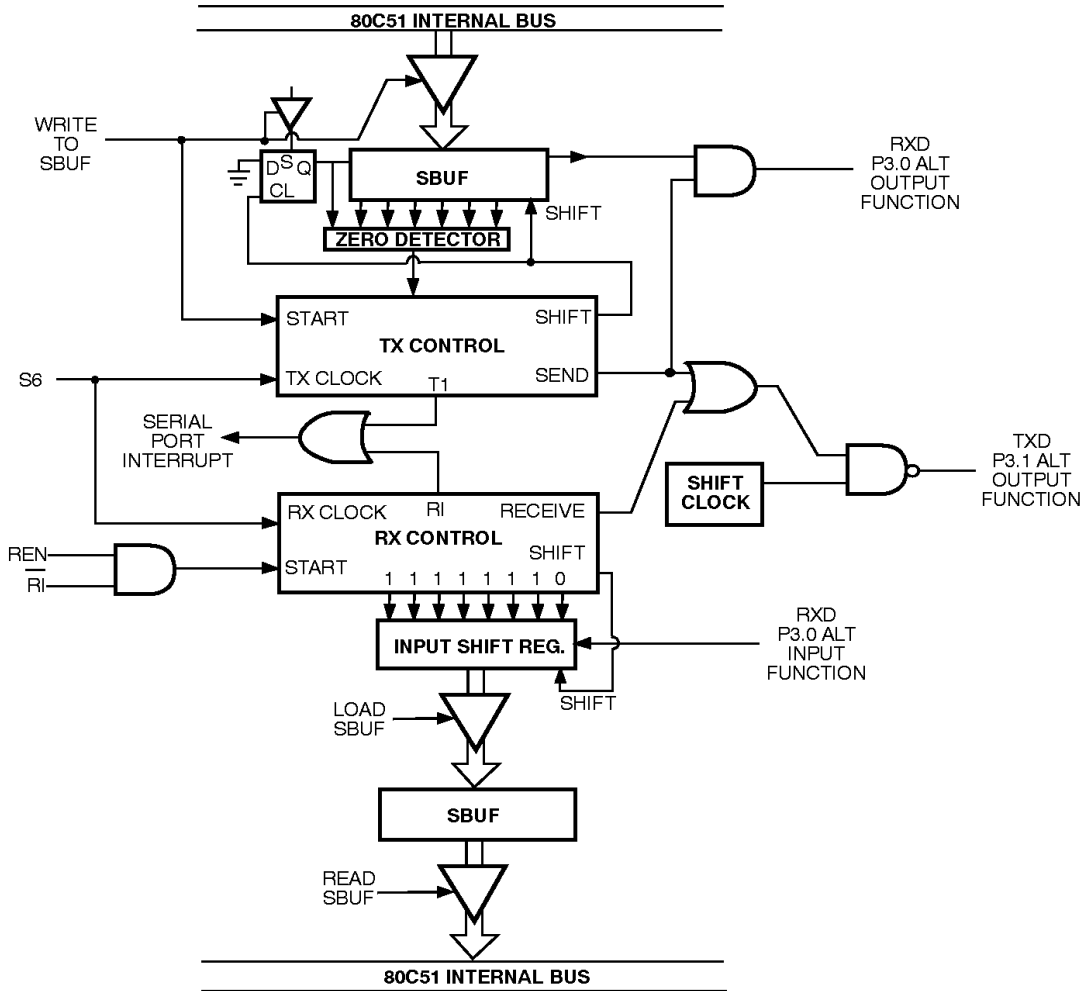

2.14 Framing Error Detection

Framing bit error detection is provided for the three asynchronous modes (modes 1, 2 and 3). To enable the framing bit error detection feature, set SMOD0 bit in PCON register (see Figure 2-25).

Figure 2-25. Framing Error Block Diagram

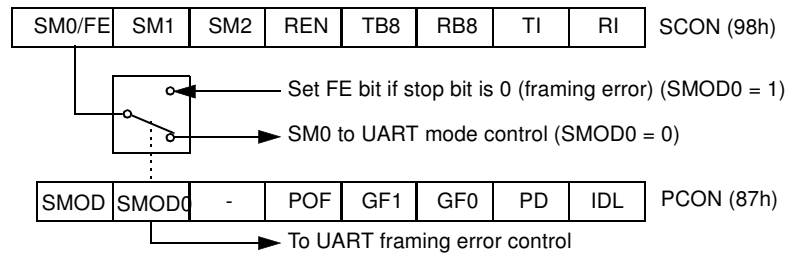

When this feature is enabled, the receiver checks each incoming data frame for a valid stop bit. An invalid stop bit may result from noise on the serial lines or from simultaneous transmission by two CPUs. If a valid stop bit is not found, the Framing Error bit (FE) in SCON register (see Table 2-17) bit is set.

Software may examine FE bit after each reception to check for data errors. Once set, only software or a reset can clear FE bit. Subsequently received frames with valid stop bits cannot clear FE bit. When FE feature is enabled, RI rises on stop bit instead of the last data bit (see Figure 2-26 and Figure 2-27).

Figure 2-26. UART Timings in Mode 1

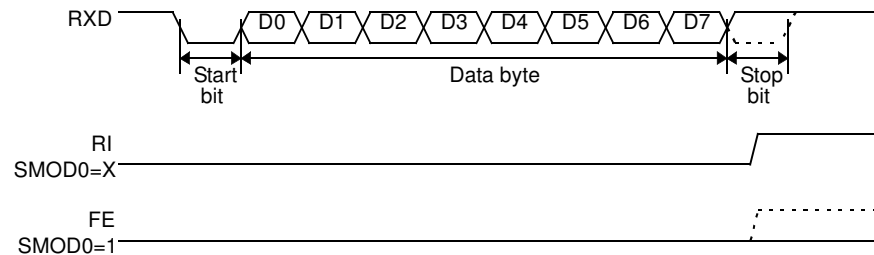
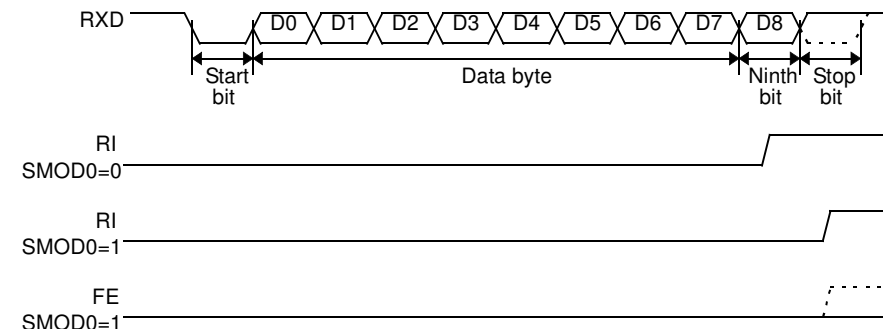

Figure 2-27. UART Timings in Modes 2 and 3



2.15 Automatic Address Recognition

2.15.1 Multiprocessor Communications

Implemented in hardware, automatic address recognition enhances the multiprocessor communication feature by allowing the serial port to examine the address of each incoming command frame. Only when the serial port recognizes its own address, the receiver sets RI bit in SCON register to generate an interrupt. This ensures that the CPU is not interrupted by command frames addressed to other devices.

To support automatic address recognition, a device is identified by a given address and a broadcast address.

Note: The multiprocessor communication and automatic address recognition features cannot be enabled in mode 0 (i.e. setting SM2 bit in SCON register in mode 0 has no effect).

If desired, you may enable the automatic address recognition feature in mode 1. In this configuration, the stop bit takes the place of the ninth data bit. Bit RI is set only when the received command frame address matches the device's address and is terminated by a valid stop bit.

Modes 2 and 3 have a special provision for multiprocessor, communications. In these modes, 9 data bits are received. The 9th one goes into RB8. Then comes a stop bit. The port can be programmed such that when the stop bit is received, the serial port interrupt will be activated only if RB8 = 1. This feature is enabled by setting bit SM2 in SCON. A way to use this feature in multiprocessor systems is as follows.

When the master processor wants to transmit a block of data to one of several slaves, it first sends out an address byte which identifies the target slave. An address byte differs from a data byte in that the 9th bit is 1 in an address byte and 0 in a data byte. With SM2 = 1, no slave will be interrupt by a data byte. An address byte, however, will interrupt all slaves, so that each slave can examine the received byte and see if it is being addressed. The addressed slave will clear its SM2 bit and prepare to receive the data bytes that will be coming. The slaves that weren't being addressed leaved their SM2s set and go on about their business, ignoring the coming data bytes.

SM2 has no effect in Mode 0, and in Mode 1 can be used to check the validity of the stop bit. In a Mode 1 reception, if SM2 = 1, the receive interrupt will not be activated unless a valid stop bit is received.

2.15.2 Given Address

Each device has an individual address that is specified in SADDR register; the SADEN register is a mask byte that contains don't-care bits (defined by zeros) to form the device's given address. The don't-care bits provide the flexibility to address one or more slaves at a time. The following example illustrates how a given address is formed.

To address a device by its individual address, the SADEN mask byte must be 1111 1111b.

For example:

```
SADDR0101 0110b
SADEN1111 1100b
Given0101 01XXb
```

The following is an example of how to use given addresses to address different slaves:

```
Slave A: SADDR1111 0001b
SADEN1111 1010b
Given1111 0X0Xb
```

```
Slave B:SADDR1111 0011b
      SADEN1111 1001b
      Given1111 0XX1b
```

```
Slave C:SADDR1111 0011b
      SADEN1111 1101b
      Given1111 00X1b
```

The SADEN byte is selected so that each slave may be addressed separately.

For slave A, bit 0 (the LSB) is a don't-care bit; for slaves B and C, bit 0 is a 1. To communicate with slave A only, the master must send an address where bit 0 is clear (e.g. 1111 0000b).

For slave A, bit 1 is a 1; for slaves B and C, bit 1 is a don't care bit. To communicate with slaves B and C, but not slave A, the master must send an address with bits 0 and 1 both set (e.g. 1111 0011b).

To communicate with slaves A, B and C, the master must send an address with bit 0 set, bit 1 clear, and bit 2 clear (e.g. 1111 0001b).

2.15.3 Broadcast Address

A broadcast address is formed from the logical OR of the SADDR and SADEN registers with zeros defined as don't-care bits, e.g.:

```
SADDR 0101 0110b
SADEN 1111 1100b
Broadcast =SADDR OR SADEN1111 111Xb
```

The use of don't-care bits provides flexibility in defining the broadcast address, however in most applications, a broadcast address is FFh. The following is an example of using broadcast addresses:

```
Slave A:SADDR1111 0001b
      SADEN1111 1010b
      Broadcast1111 1X11b,
```

```
Slave B:SADDR1111 0011b
      SADEN1111 1001b
      Broadcast1111 1X11b,
```

```
Slave C:SADDR=1111 0010b
      SADEN1111 1101b
      Broadcast1111 1111b
```

For slaves A and B, bit 2 is a don't care bit; for slave C, bit 2 is set. To communicate with all of the slaves, the master must send an address FFh. To communicate with slaves A and B, but not slave C, the master can send an address FBh.

2.15.4 Reset Addresses

On reset, the SADDR and SADEN registers are initialized to 00h, i.e. the given and broadcast addresses are XXXX XXXXb (all don't-care bits). This ensures that the serial port will reply to any address, and thus, that it is backwards compatible with the 80C51 microcontrollers that do not support automatic address recognition.

Table 2-17. SADEN Register
SADEN - Slave Address Mask Register (B9h)

7	6	5	4	3	2	1	0

Reset Value = 0000 0000b
Not bit addressable

Table 2-18. SADDR Register
SADDR - Slave Address Register (A9h)

7	6	5	4	3	2	1	0

Reset Value = 0000 0000b
Not bit addressable

UART Registers

Table 2-19. SCON Register

SCON - Serial Control Register (98h)

7	6	5	4	3	2	1	0
FE/SM0	SM1	SM2	REN	TB8	RB8	TI	RI
Bit Number	Bit Mnemonic	Description					
7	FE	Framing Error bit (SMOD0=1) Clear to reset the error state, not cleared by a valid stop bit. Set by hardware when an invalid stop bit is detected. SMOD0 must be set to enable access to the FE bit					
	SM0	Serial port Mode bit 0 Refer to SM1 for serial port mode selection. SMOD0 must be cleared to enable access to the SM0 bit					
6	SM1	Serial port Mode bit 1					
		SM0	SM1	Mode	Description	Baud Rate	
		0	0	0	Shift Register	$F_{CPU PERIPH}/6$	
		0	1	1	8-bit UART	Variable	
		1	0	2	9-bit UART	$F_{CPU PERIPH}/32$ or $/16$	
1	1	3	9-bit UART	Variable			
5	SM2	Serial port Mode 2 bit / Multiprocessor Communication Enable bit Clear to disable multiprocessor communication feature. Set to enable multiprocessor communication feature in mode 2 and 3, and eventually mode 1. This bit should be cleared in mode 0.					
4	REN	Reception Enable bit Clear to disable serial reception. Set to enable serial reception.					
3	TB8	Transmitter Bit 8 / Ninth bit to transmit in modes 2 and 3. 0 transmit a logic 0 in the 9th bit. Set to transmit a logic 1 in the 9th bit.					
2	RB8	Receiver Bit 8 / Ninth bit received in modes 2 and 3 Cleared by hardware if 9th bit received is a logic 0. Set by hardware if 9th bit received is a logic 1. In mode 1, if SM2 = 0, RB8 is the received stop bit. In mode 0 RB8 is not used.					
1	TI	Transmit Interrupt flag Clear to acknowledge interrupt. Set by hardware at the end of the 8th bit time in mode 0 or at the beginning of the stop bit in the other modes.					
0	RI	Receive Interrupt flag Clear to acknowledge interrupt. Set by hardware at the end of the 8th bit time in mode 0, see Figure 2-26. and Figure 2-27. in the other modes.					

Reset Value = 0000 0000b

Bit addressable

Table 2-20. SADEN Register

SADEN - Slave Address Mask Register for UART (B9h)

7	6	5	4	3	2	1	0

Reset Value = 0000 0000b

Table 2-21. SADDR Register

SADDR - Slave Address Register for UART (A9h)

7	6	5	4	3	2	1	0

Reset Value = 0000 0000b

Table 2-22. SBUF Register

SBUF - Serial Buffer Register for UART (99h)

7	6	5	4	3	2	1	0

Reset Value = XXXX XXXXb

Table 2-23. BRL Register

BRL - Baud Rate Reload Register for the internal baud rate generator, UART (9Ah)

7	6	5	4	3	2	1	0

Reset Value = 0000 0000b

Table 2-24. T2CON Register
T2CON - Timer2 Control Register (C8h)

7	6	5	4	3	2	1	0
TF2	EXF2	RCLK	TCLK	EXEN2	TR2	C/T2#	CP/RL2#
Bit Number	Bit Mnemonic	Description					
7	TF2	Timer 2 overflow Flag Must be cleared by software. Set by hardware on timer 2 overflow, if RCLK = 0 and TCLK = 0.					
6	EXF2	Timer 2 External Flag Set when a capture or a reload is caused by a negative transition on T2EX pin if EXEN2=1. When set, causes the CPU to vector to timer 2 interrupt routine when timer 2 interrupt is enabled. Must be cleared by software. EXF2 doesn't cause an interrupt in Up/down counter mode (DCEN = 1)					
5	RCLK	Receive Clock bit for UART Cleared to use timer 1 overflow as receive clock for serial port in mode 1 or 3. Set to use timer 2 overflow as receive clock for serial port in mode 1 or 3.					
4	TCLK	Transmit Clock bit for UART Cleared to use timer 1 overflow as transmit clock for serial port in mode 1 or 3. Set to use timer 2 overflow as transmit clock for serial port in mode 1 or 3.					
3	EXEN2	Timer 2 External Enable bit Cleared to ignore events on T2EX pin for timer 2 operation. Set to cause a capture or reload when a negative transition on T2EX pin is detected, if timer 2 is not used to clock the serial port.					
2	TR2	Timer 2 Run control bit Cleared to turn off timer 2. Set to turn on timer 2.					
1	C/T2#	Timer/Counter 2 select bit Cleared for timer operation (input from internal clock system: F _{CLK PERIPH}). Set for counter operation (input from T2 input pin, falling edge trigger). Must be 0 for clock out mode.					
0	CP/RL2#	Timer 2 Capture/Reload bit If RCLK=1 or TCLK=1, CP/RL2# is ignored and timer is forced to auto-reload on timer 2 overflow. Cleared to auto-reload on timer 2 overflows or negative transitions on T2EX pin if EXEN2=1. Set to capture on negative transitions on T2EX pin if EXEN2=1.					

Reset Value = 0000 0000b

Bit addressable

Table 2-25. PCON Register
PCON - Power Control Register (87h)

7	6	5	4	3	2	1	0
SMOD1	SMOD0	-	POF	GF1	GF0	PD	IDL
Bit Number	Bit Mnemonic	Description					
7	SMOD1	Serial port Mode bit 1 for UART Set to select double baud rate in mode 1, 2 or 3.					
6	SMOD0	Serial port Mode bit 0 for UART Cleared to select SM0 bit in SCON register. Set to select FE bit in SCON register.					
5	-	Reserved The value read from this bit is indeterminate. Do not set this bit.					
4	POF	Power-Off Flag Cleared to recognize next reset type. Set by hardware when VCC rises from 0 to its nominal voltage. Can also be set by software.					
3	GF1	General purpose Flag Cleared by user for general purpose usage. Set by user for general purpose usage.					
2	GF0	General purpose Flag Cleared by user for general purpose usage. Set by user for general purpose usage.					
1	PD	Power-Down mode bit Cleared by hardware when reset occurs. Set to enter power-down mode.					
0	IDL	Idle mode bit Cleared by hardware when interrupt or reset occurs. Set to enter idle mode.					

Reset Value = 00X1 0000b

Not bit addressable

Power-off flag reset value will be 1 only after a power on (cold reset). A warm reset doesn't affect the value of this bit.

Table 2-26. BDRCON Register
BDRCON - Baud Rate Control Register (9Bh)

7	6	5	4	3	2	1	0	
-	-	-	BRR	TBCK	RBCK	SPD	SRC	
Bit Number	Bit Mnemonic	Description						
7	-	Reserved The value read from this bit is indeterminate. Do not set this bit						
6	-	Reserved The value read from this bit is indeterminate. Do not set this bit						
5	-	Reserved The value read from this bit is indeterminate. Do not set this bit.						
4	BRR	Baud Rate Run Control bit Cleared to stop the internal Baud Rate Generator. Set to start the internal Baud Rate Generator.						
3	TBCK	Transmission Baud rate Generator Selection bit for UART Cleared to select Timer 1 or Timer 2 for the Baud Rate Generator. Set to select internal Baud Rate Generator.						
2	RBCK	Reception Baud Rate Generator Selection bit for UART Cleared to select Timer 1 or Timer 2 for the Baud Rate Generator. Set to select internal Baud Rate Generator.						
1	SPD	Baud Rate Speed Control bit for UART Cleared to select the SLOW Baud Rate Generator. Set to select the FAST Baud Rate Generator.						
0	SRC	Baud Rate Source select bit in Mode 0 for UART Cleared to select $F_{OSC}/12$ as the Baud Rate Generator ($F_{CLK_PERIPH}/6$ in X2 mode). Set to select the internal Baud Rate Generator for UARTs in mode 0.						

Reset Value = XXX0 0000b

Not bit addressable

2.16 Interrupts

If two requests of different priority levels are received simultaneously, the request of higher priority level is serviced. If requests of the same priority level are received simultaneously, an internal polling sequence determine which request is serviced, Thus within each priority level is a second priority structure determined by the polling sequence, as follows:

Table 2-27. Interrupt Priority Level

	Source	Priority Within Level
1	IE0	(highest)
2	TF0	
3	IE1	
4	TF1	
5	RI + TI	
6	TF2 + EXF2	(lowest)

Note that the "priority within level" structure is only used to resolve simultaneous requests of the same priority level.

2.16.1 How Interrupts Are Handled

The interrupt flags are sampled at S5P2 of every machine cycle. The samples are polled during the following machine cycle. If one of the flags was in a set condition at S5P2 of the preceding cycle, the polling cycle will find it and the interrupt system will generate an LCALL to the appropriate service routine, provided this hardware-generated LCALL is not clocked by any of the following conditions:

1. An interrupt of equal or higher priority level is already in progress.
2. The current (polling) cycle is not the final cycle in the execution of the instruction in progress.
3. The instruction in progress is RETI or any access to the IE or IP registers.

The polling cycle is repeated with each machine cycle, and the values polled are the values that were present at S5P2 of the previous machine cycle. Note then that if an interrupt flag is active but not being responded to for one of the above conditions, if the flag is not still active when the blocking condition is removed, the denied interrupt will not be serviced. In other words, the facts that the interrupt flag was once active but not serviced is not remembered. Every polling cycle is new.

The polling cycle/LCALL sequence is illustrated in Figure 2-28.

Note that if an interrupt of higher priority level goes active prior to S5P2 of the machine cycle labeled C3 in Figure 2-28, then in accordance with the above rules it will be vectored to during CS and C6, without any instruction of the lower priority routine having been executed.

Figure 2-28. Interrupt Response Timing Diagram

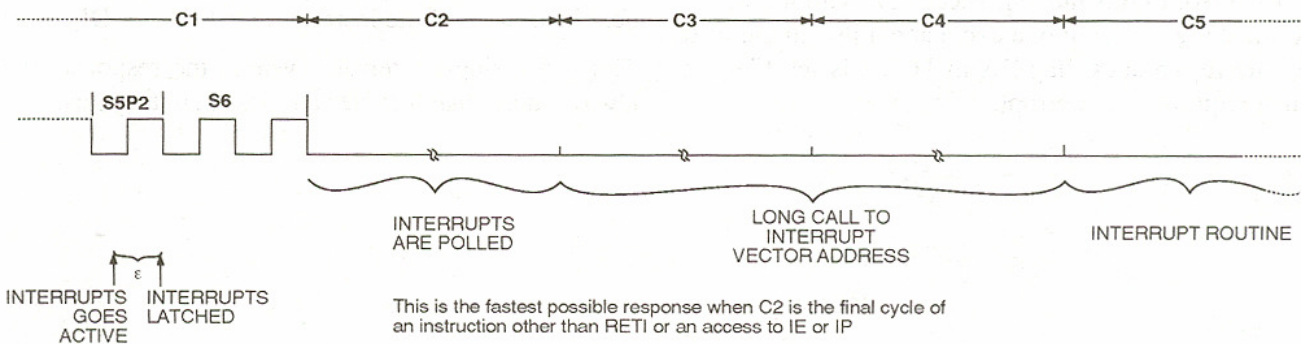

Thus the processor acknowledges an interrupt request by executing a hardware generated LCALL to the appropriate servicing routine. In some cases it also clears the flag that generated the interrupt, and in other cases it doesn't. It never clears the Serial Port or Timers 2 flags. This has to be done in the user's software. It clears an external interrupt flag (IE0 or IE1) only if it was transition-activated.

The hardware-generated LCALL pushes the contents of the Program Counter onto the stack (but it does not save the PSW) and reloads the PC with an address that depends on the source of the interrupt being vectored to, as shown below.

Source	Vector Address
IE0	0003H
TF0	000BH
IE1	0013H
TF1	001BH
RI + TI	0023H
TF2 + EXF2	002BH

Execution proceeds from that location until the RETI instruction is encountered. The RETI instruction informs the processor that this interrupt routine is no longer in progress, then pops the top two bytes from the stack and reloads the Program Counter. Execution of the interrupted program continues from where it left off.

Note that a simple RET instruction would also have returned execution to the interrupted program, but it would have left the interrupt control system thinking an interrupt was still in progress.

2.16.2 External Interrupts

The external sources can be programmed to be level-activated or transition-activated by setting or clearing bit IT1 or ITO in Register TCON.

If $IT_x = 0$, external interrupt x is triggered by a detected low at the \overline{INT}_x pin. If $IT_x = 1$, external interrupt x is edge-triggered. In this mode if successive samples of the \overline{INT}_x pin show a high in one cycle and a low in the next cycle, interrupt request flag IE_x in TCON is set. Flag bit IE_x then requests the interrupt.

Since the external interrupt pins are sampled once each machine cycle, an input high or low should hold for at least 12 oscillator periods to ensure sampling. If the external interrupt is transition-activated, the external source has to hold the request pin high for at least one cycle, and then hold it low for at least one cycle to ensure that the transition is seen so that interrupt request flag IE_x will be set. IE_x will be automatically cleared by the CPU when the service routine is called.

If the external interrupt is level-activated, the external source has to hold the request active until the requested interrupt is actually generated. Then it has to deactivate the request before the interrupt service routine is completed, or else another interrupt will be generated.

2.16.3 Response Time

The \overline{INT}_0 and \overline{INT}_1 levels are inverted and latched into IE_0 and IE_1 and $S5P_2$ of every machine cycle. The values are not actually polled by the circuitry until the next machine cycle. If a request is active and conditions are right for it to be acknowledged, a hardware subroutine call to the requested service routine will be the next instruction to be executed. The call itself takes two cycles. Thus, a minimum of three complete machine cycles elapse between activation of an external interrupt request and the beginning of execution of the service routine. Figure 29. shows interrupt response timings.

A longer response time would result if the request is blocked by one of the 3 previously listed conditions. If an interrupt of equal or higher priority level is already in progress, the additional wait time obviously depends on the nature of the other interrupt's service routine. If the instruction in progress is not in its final cycle, the additional wait time cannot be more than 3 cycles, since the longest instructions (MUL and DIV) are only 4 cycles long, and if the instruction in progress is RETI or an access to IE or IP, the additional wait time cannot be more than 5 cycles (a maximum of one more cycle to

Common Features Description

complete the instruction in progress, plus 4 cycles to complete the next instruction if the instruction is MUL or DIV).

Thus, in a single-interrupt system, the response time is always more than 3 cycles and less than 8 cycles.



Atmel Corporation

2325 Orchard Parkway
San Jose, CA 95131, USA
Tel: 1(408) 441-0311
Fax: 1(408) 487-2600

Regional Headquarters

Europe

Atmel Sarl
Route des Arsenaux 41
Case Postale 80
CH-1705 Fribourg
Switzerland
Tel: (41) 26-426-5555
Fax: (41) 26-426-5500

Asia

Room 1219
Chinachem Golden Plaza
77 Mody Road Tsimshatsui
East Kowloon
Hong Kong
Tel: (852) 2721-9778
Fax: (852) 2722-1369

Japan

9F, Tonetsu Shinkawa Bldg.
1-24-8 Shinkawa
Chuo-ku, Tokyo 104-0033
Japan
Tel: (81) 3-3523-3551
Fax: (81) 3-3523-7581

Atmel Operations

Memory

2325 Orchard Parkway
San Jose, CA 95131, USA
Tel: 1(408) 441-0311
Fax: 1(408) 436-4314

Microcontrollers

2325 Orchard Parkway
San Jose, CA 95131, USA
Tel: 1(408) 441-0311
Fax: 1(408) 436-4314

La Chantrerie
BP 70602
44306 Nantes Cedex 3, France
Tel: (33) 2-40-18-18-18
Fax: (33) 2-40-18-19-60

ASIC/ASSP/Smart Cards

Zone Industrielle
13106 Rousset Cedex, France
Tel: (33) 4-42-53-60-00
Fax: (33) 4-42-53-60-01

1150 East Cheyenne Mtn. Blvd.
Colorado Springs, CO 80906, USA
Tel: 1(719) 576-3300
Fax: 1(719) 540-1759

Scottish Enterprise Technology Park
Maxwell Building
East Kilbride G75 0QR, Scotland
Tel: (44) 1355-803-000
Fax: (44) 1355-242-743

RF/Automotive

Theresienstrasse 2
Postfach 3535
74025 Heilbronn, Germany
Tel: (49) 71-31-67-0
Fax: (49) 71-31-67-2340

1150 East Cheyenne Mtn. Blvd.
Colorado Springs, CO 80906, USA
Tel: 1(719) 576-3300
Fax: 1(719) 540-1759

Biometrics/Imaging/Hi-Rel MPU/ High Speed Converters/RF Datacom

Avenue de Rochepleine
BP 123
38521 Saint-Egreve Cedex, France
Tel: (33) 4-76-58-30-00
Fax: (33) 4-76-58-34-80

Literature Requests

www.atmel.com/literature

Disclaimer: The information in this document is provided in connection with Atmel products. No license, express or implied, by estoppel or otherwise, to any intellectual property right is granted by this document or in connection with the sale of Atmel products. **EXCEPT AS SET FORTH IN ATMEL'S TERMS AND CONDITIONS OF SALE LOCATED ON ATMEL'S WEB SITE, ATMEL ASSUMES NO LIABILITY WHATSOEVER AND DISCLAIMS ANY EXPRESS, IMPLIED OR STATUTORY WARRANTY RELATING TO ITS PRODUCTS INCLUDING, BUT NOT LIMITED TO, THE IMPLIED WARRANTY OF MERCHANTABILITY, FITNESS FOR A PARTICULAR PURPOSE, OR NON-INFRINGEMENT. IN NO EVENT SHALL ATMEL BE LIABLE FOR ANY DIRECT, INDIRECT, CONSEQUENTIAL, PUNITIVE, SPECIAL OR INCIDENTAL DAMAGES (INCLUDING, WITHOUT LIMITATION, DAMAGES FOR LOSS OF PROFITS, BUSINESS INTERRUPTION, OR LOSS OF INFORMATION) ARISING OUT OF THE USE OR INABILITY TO USE THIS DOCUMENT, EVEN IF ATMEL HAS BEEN ADVISED OF THE POSSIBILITY OF SUCH DAMAGES.** Atmel makes no representations or warranties with respect to the accuracy or completeness of the contents of this document and reserves the right to make changes to specifications and product descriptions at any time without notice. Atmel does not make any commitment to update the information contained herein. Atmel's products are not intended, authorized, or warranted for use as components in applications intended to support or sustain life.

©2007 Atmel Corporation . All rights reserved. Atmel®, logo and combinations thereof, are registered trademarks, and Everywhere You Are® are the trademarks of Atmel Corporation or its subsidiaries. Copied by permission of Intel Corporation. Copyright Intel Corporation 1980, 1982. Other terms and product names may be trademarks of others.



Printed on recycled paper.