



# MAZHIDA MOTOR

Carbon-brush motors



Typical Application:  
toys and model  
massager vibrator  
Handicraft  
auto rearview mirror

## FC280RA/SA

MODEL	VOLTAGE		NO LOAD		AT MAXIMUM EFFICIENCY					STALL TORQUE	
	Operating range	Nominal	Speed	Current	Speed	Current	Torque	Output	Eff.	Current	Torque
	(V)	(V)	(r/min)	(A)	(r/min)	(A)	(g. cm)	(W)	(%)	(A)	(g. cm)
FC280RA-2865	1.5 - 4.5	2.4	7900	0.22	6170	0.81	14.7	0.93	48.1	2.89	67
		3.0	10000	0.23	7980	0.91	16.9	1.39	50.8	3.6	84
FC280SA-2585	3.0 - 6.0	6.0	12100	0.19	10180	1.01	34.3	5.58	59.4	5.32	216
FC280SA-20130	6.0 - 12.0	9.0	12000	0.16	9780	0.7	35.2	3.53	55.7	3.1	190
FC280SA-18100	10.0 - 15.0	12.0	20800	0.22	16660	0.89	44.4	7.59	71.4	3.56	223

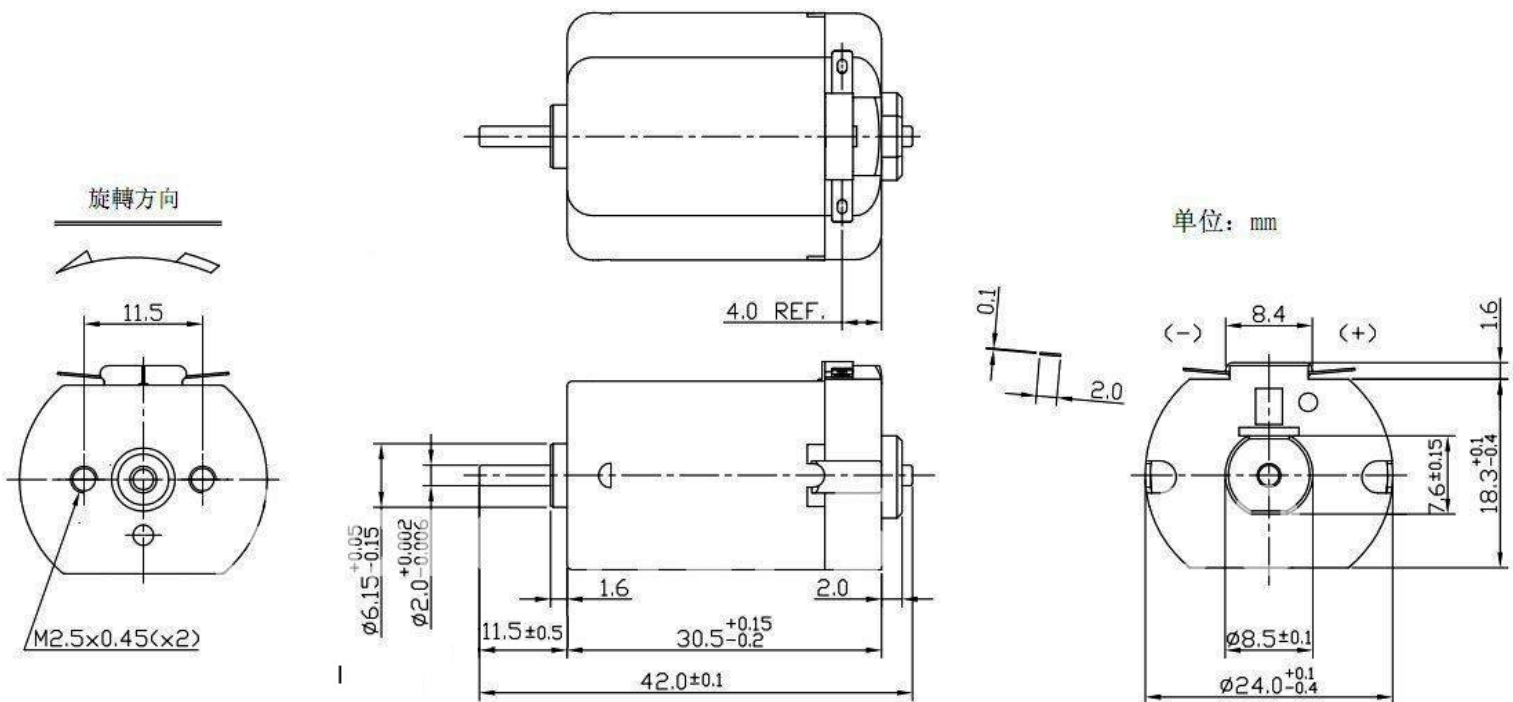

重量: 36g(大約)

# FC280RA-2865

$\eta$  P I N

75 1.5 6.0 12000

50 1.0 4.0 8000

25 0.5 2.0 4000

0 0 0 0  
 Eff. (%)  
 Power (W)  
 Current (A)  
 Speed (RPM)

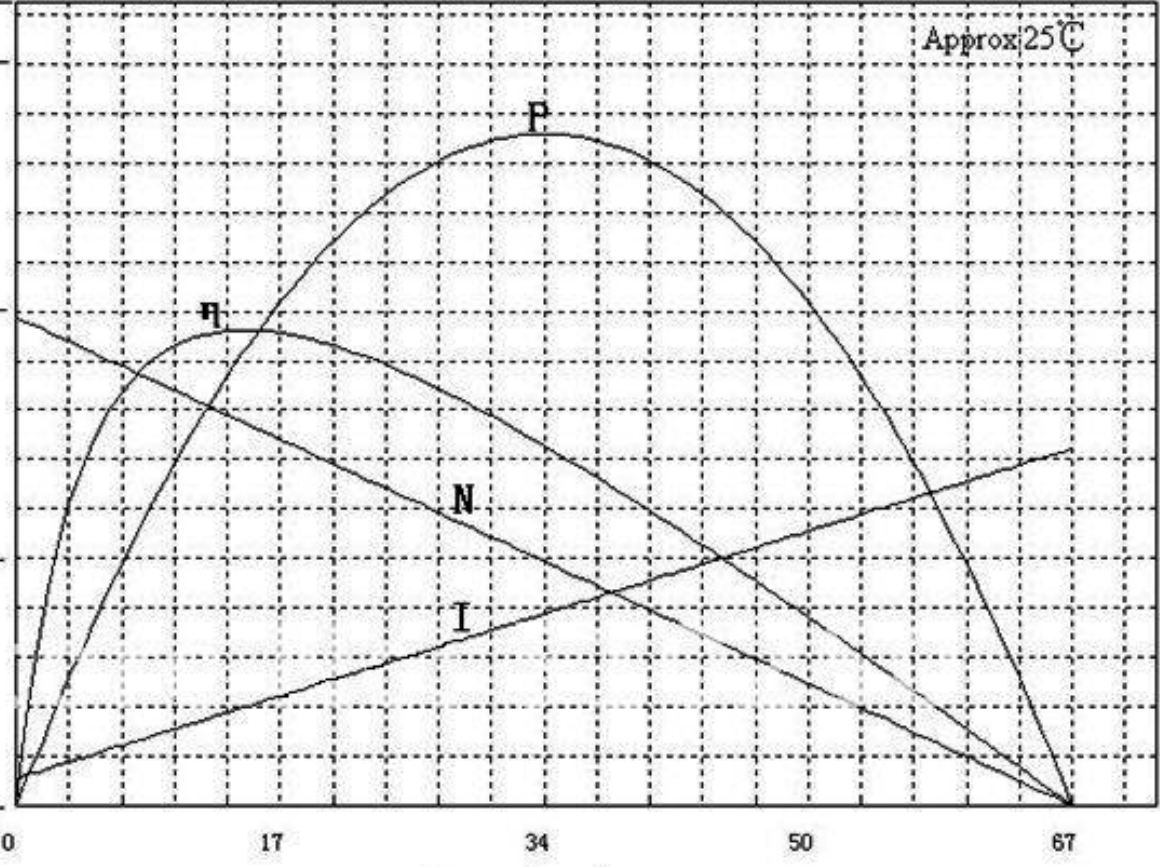

(NOTE: 1mN.m = 10.2g.cm)

# FC280SA-18100

$\eta$	P	I	N
75	15.0	6.00	30000
50	10.0	4.00	20000
25	5.0	2.00	10000
0	0.0	0	0
Eff. (%)	Power (W)	Current (A)	Speed (RPM)

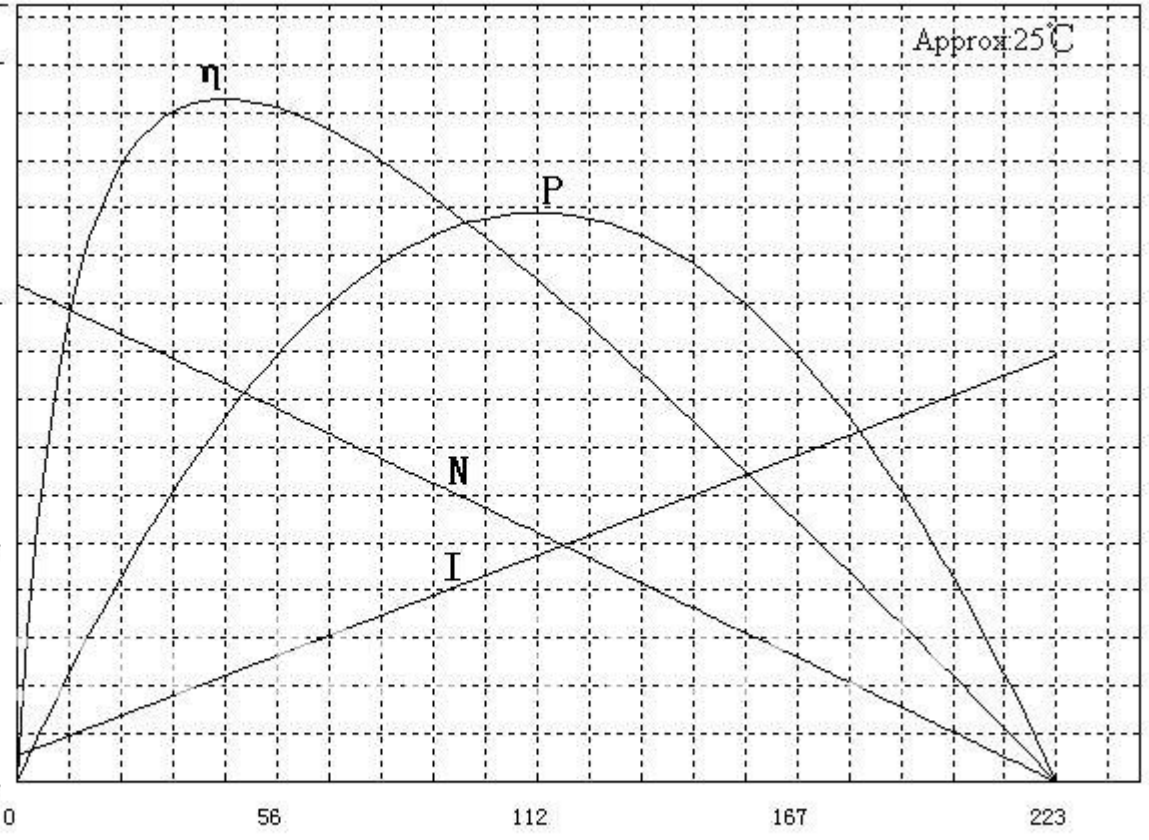

(NOTE: 1mN.m = 10.2g.cm)