

HD74LS123

Dual Retriggerable Monostable Multivibrators (with Clear)

REJ03D0429-0200
Rev.2.00
Feb.18.2005

This d-c triggered multivibrator features output pulse width control by three method. The basic pulse time is programmed by selection of external resistance and capacitance values. Once triggered, the basic pulse width may be extended by retriggering the gated low-level -active (A) or high-level active (B) inputs, or be reduced by use of the overriding clear. Figure 1 illustrates pulse control by retriggering and early clear. This device is provided enough Schmitt hysteresis to ensure jitter-free triggering from the B input with transition rates as slow as 0.1 mV/ns.

Features

- Ordering Information

Part Name	Package Type	Package Code (Previous Code)	Package Abbreviation	Taping Abbreviation (Quantity)
HD74LS123P	DILP-16 pin	PRDP0016AE-B (DP-16FV)	P	—
HD74LS123FPEL	SOP-16 pin (JEITA)	PRSP0016DH-B (FP-16DAV)	FP	EL (2,000 pcs/reel)
HD74LS123RPEL	SOP-16 pin (JEDEC)	PRSP0016DG-A (FP-16DNV)	RP	EL (2,500 pcs/reel)

Note: Please consult the sales office for the above package availability.

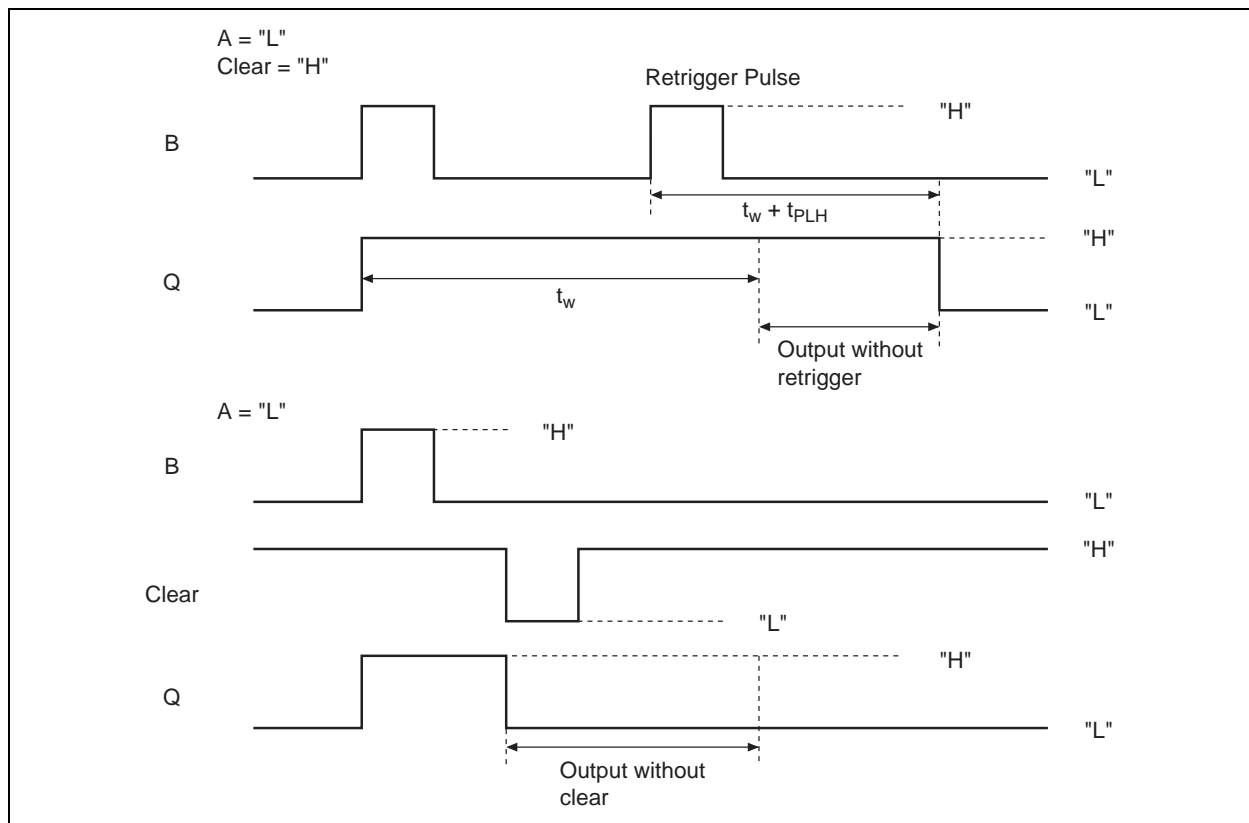
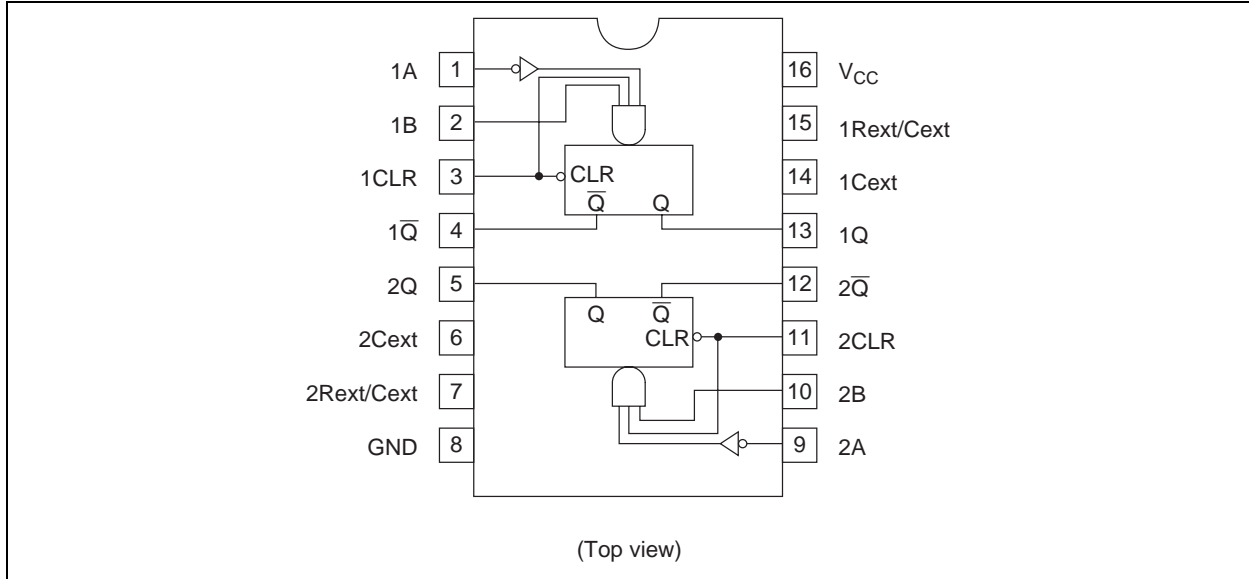

Figure 1 Typical Input / Output Pulse

Pin Arrangement



Function Table

Inputs			Outputs	
Clear	A ₁	B ₂	Q	Q̄
L	X	X	L	H
X	H	X	L	H
X	X	L	L	H
H	L	↑	⌋	⌋
H	↓	H	⌋	⌋
↑	L	H	⌋	⌋

Notes: H; high level, L; low level, X; irrelevant
 ↑; transition from low to high level
 ↓; transition from high to low level
 ⌋; one high-level pulse
 ⌋; one low-level pulse

Block Diagram (1/2)

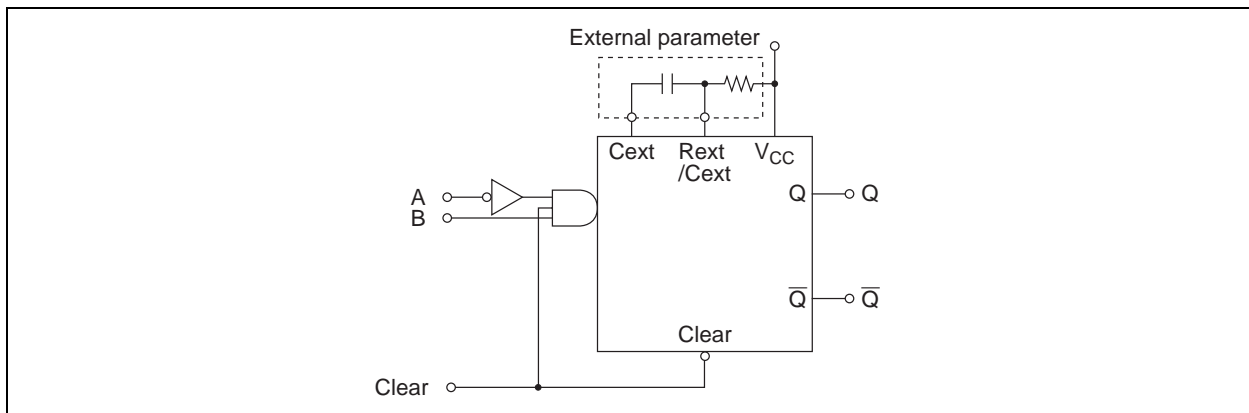

Absolute Maximum Ratings

Item	Symbol	Ratings	Unit
Supply voltage	V_{CC}	7	V
Input voltage	V_{IN}	7	V
Power dissipation	P_T	400	mW
Storage temperature	T_{stg}	-65 to +150	°C

Note: Voltage value, unless otherwise noted, are with respect to network ground terminal.

Recommended Operating Conditions

Item	Symbol	Min	Typ	Max	Unit
Supply voltage	V_{CC}	4.75	5.00	5.25	V
Output current	I_{OH}	—	—	-400	μA
	I_{OL}	—	—	8	mA
Operating temperature	T_{opr}	-20	25	75	°C
Input pulse width	A, B	"H"	t_w (in)	40	ns
		"L"		40	ns
	CLR	"L"		40	ns
External timing resistance	R_{ext}	5	—	260	k Ω
External capacitance	C_{ext}	Non restriction			
Wiring capacitance at R_{ext}/C_{ext} terminal		—	—	50	pF

Electrical Characteristics

($T_a = -20$ to $+75$ °C)

Item	Symbol	min.	typ.*	max.	Unit	Condition
Input voltage	V_{IH}	2.0	—	—	V	
	V_{IL}	—	—	0.8	V	
Output voltage	V_{OH}	2.7	—	—	V	$V_{CC} = 4.75$ V, $V_{IH} = 2$ V, $V_{IL} = 0.8$ V, $I_{OH} = -400$ μA
	V_{OL}	—	—	0.4	V	$V_{CC} = 4.75$ V, $V_{IH} = 2$ V, $V_{IL} = 0.8$ V
—		—	0.5			
Input current	I_{IH}	—	—	20	μA	$V_{CC} = 5.25$ V, $V_I = 2.7$ V
	I_{IL}	—	—	-0.4	mA	$V_{CC} = 5.25$ V, $V_I = 0.4$ V
	I_I	—	—	0.1	mA	$V_{CC} = 5.25$ V, $V_I = 7$ V
Short-circuit output current	I_{OS}	-20	—	-100	mA	$V_{CC} = 5.25$ V
Supply current**	I_{CC}	—	12	20	mA	$V_{CC} = 5.25$ V
Input clamp voltage	V_{IK}	—	—	-1.5	V	$V_{CC} = 4.75$ V, $I_{IN} = -18$ mA

* $V_{CC} = 5$ V, $T_a = 25$ °C

** With all outputs open and 4.5 V applied to all data and clear inputs, I_{CC} is measured after a momentary ground, then 4.5 V, is applied to clock.

Note: To measure V_{OH} at Q, V_{OL} at \bar{Q} , or I_{OS} at Q, ground R_{ext} / C_{ext} , apply 2 V to B and clear, and pulse A from 2 V to 0 V.

Switching Characteristics

($V_{CC} = 5\text{ V}$, $T_a = 25^\circ\text{C}$)

Item	Symbol	Inputs	Outputs	min.	typ.	max.	Unit	Condition
Propagation delay time	t_{PLH}	A	Q	—	23	33	ns	$C_{ext} = 0$, $R_{ext} = 5\text{ k}\Omega$, $C_L = 15\text{ pF}$, $R_L = 2\text{ k}\Omega$
	t_{PHL}		\bar{Q}	—	32	45		
	t_{PLH}	B	Q	—	23	44		
	t_{PHL}		\bar{Q}	—	34	56		
	t_{PLH}	CLR	Q	—	20	27		
	t_{PHL}		\bar{Q}	—	28	45		
Output pulse width	$t_{(out)min}$	A, B	Q	—	116	200	μs	$C_{ext} = 1000\text{ pF}$, $R_{ext} = 10\text{ k}\Omega$, $C_L = 15\text{ pF}$, $R_L = 2\text{ k}\Omega$
	$t_{(out)}$		Q	4	4.5	5		

Typical Application Data for HD74LS123

For pulse widths when $C_{ext} \leq 1000\text{ pF}$, See Figure 3.

The output pulse is primarily a function of the external capacitor and resistor. For $C_{ext} > 1000\text{ pF}$, the output pulse width (t_w) is defined as: $t_{w(out)} = K \cdot R_{ext} \cdot C_{ext}$; See Figure 4.

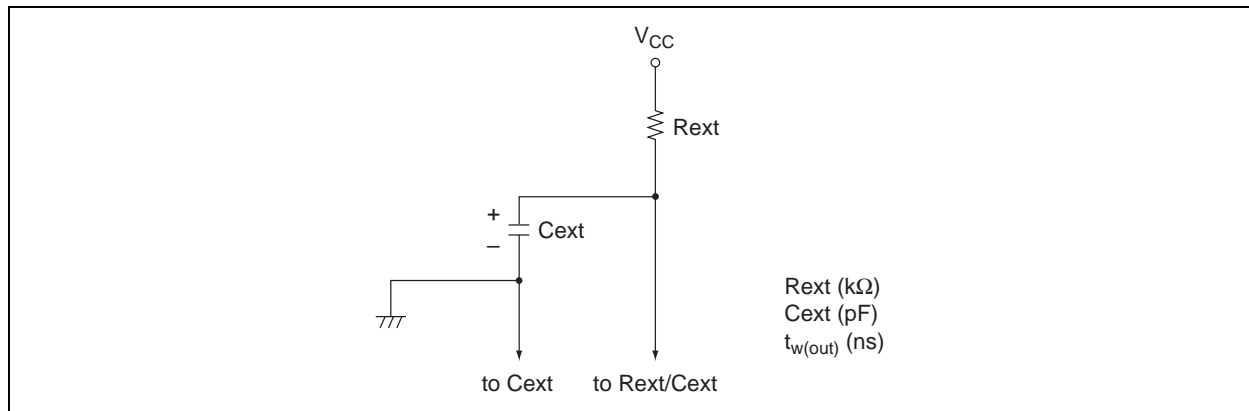

Figure 2 Timing Component Connections

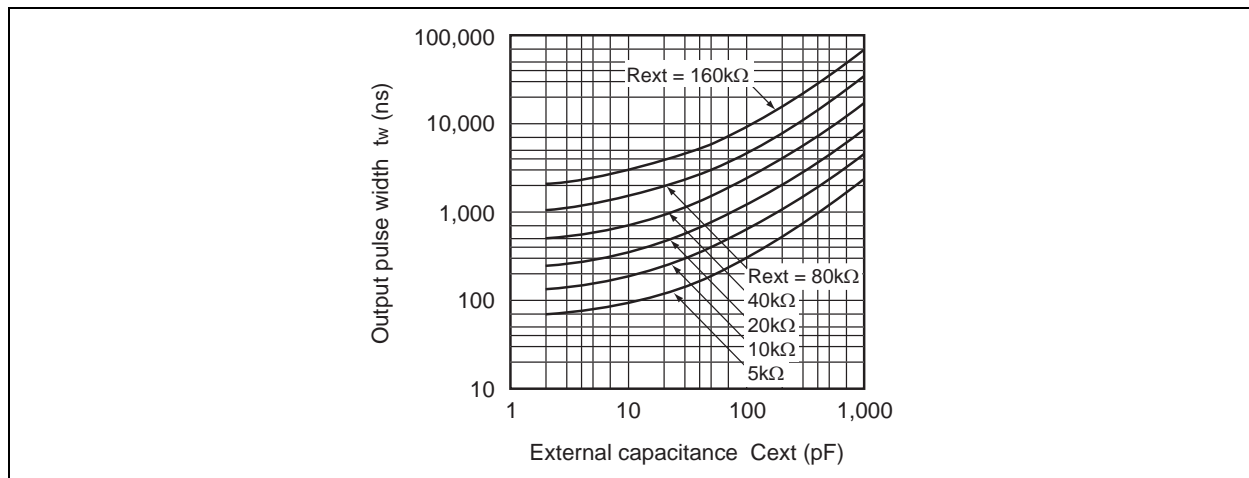

Figure 3 Typical Output Pulse Width ($C_{ext} \leq 1000\text{ pF}$)

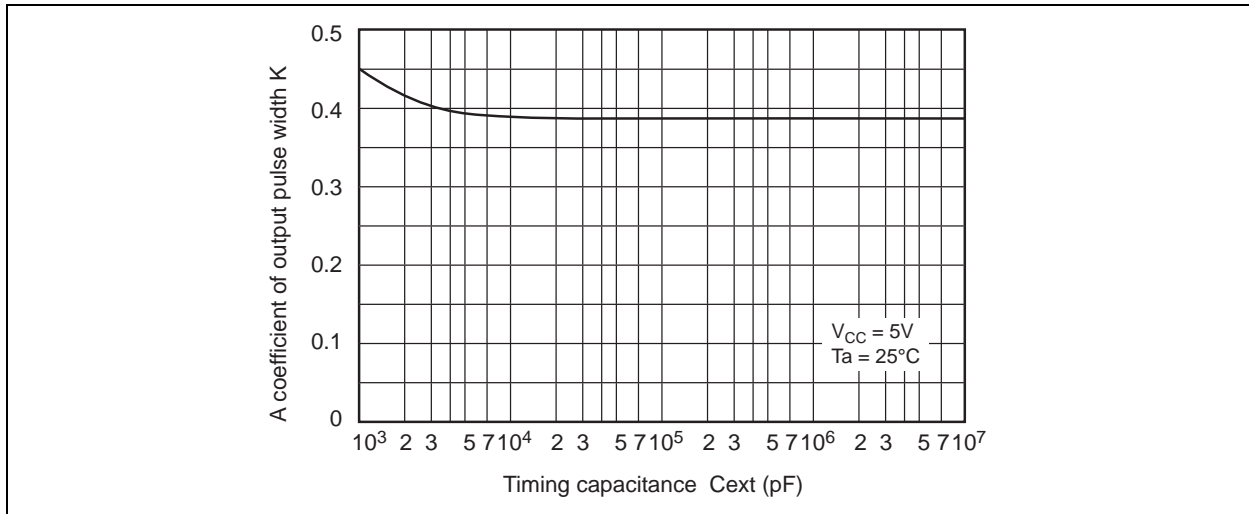
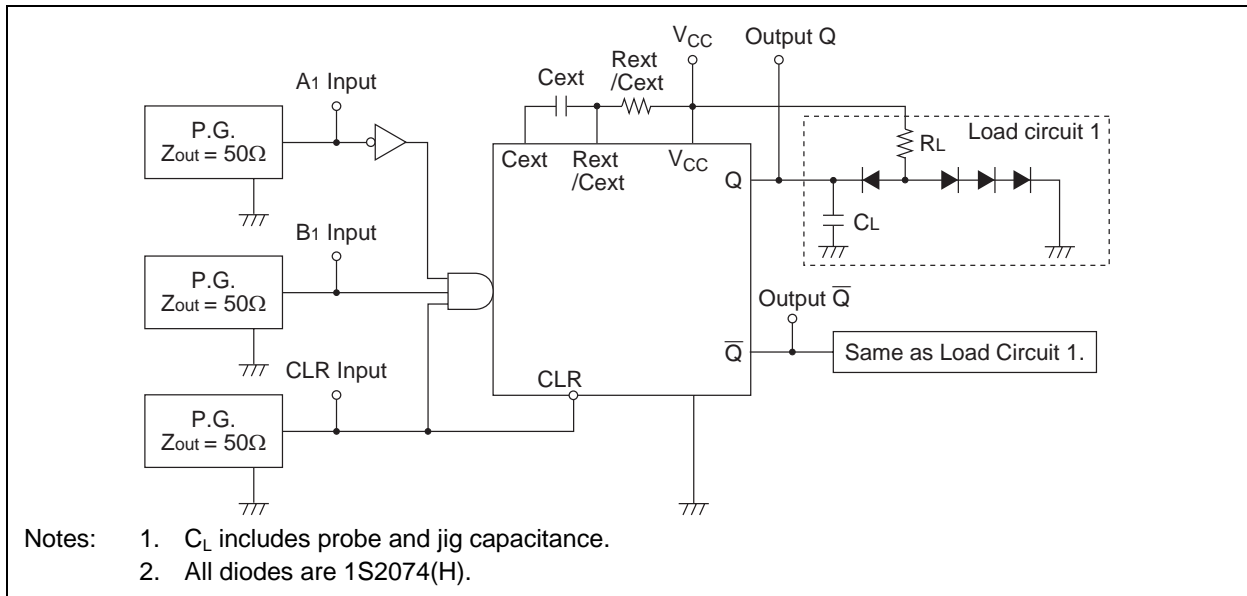

Figure 4 C_{ext} vs. K ($C_{ext} > 1000$ pF)

Testing Method

Test Circuit



Waveform

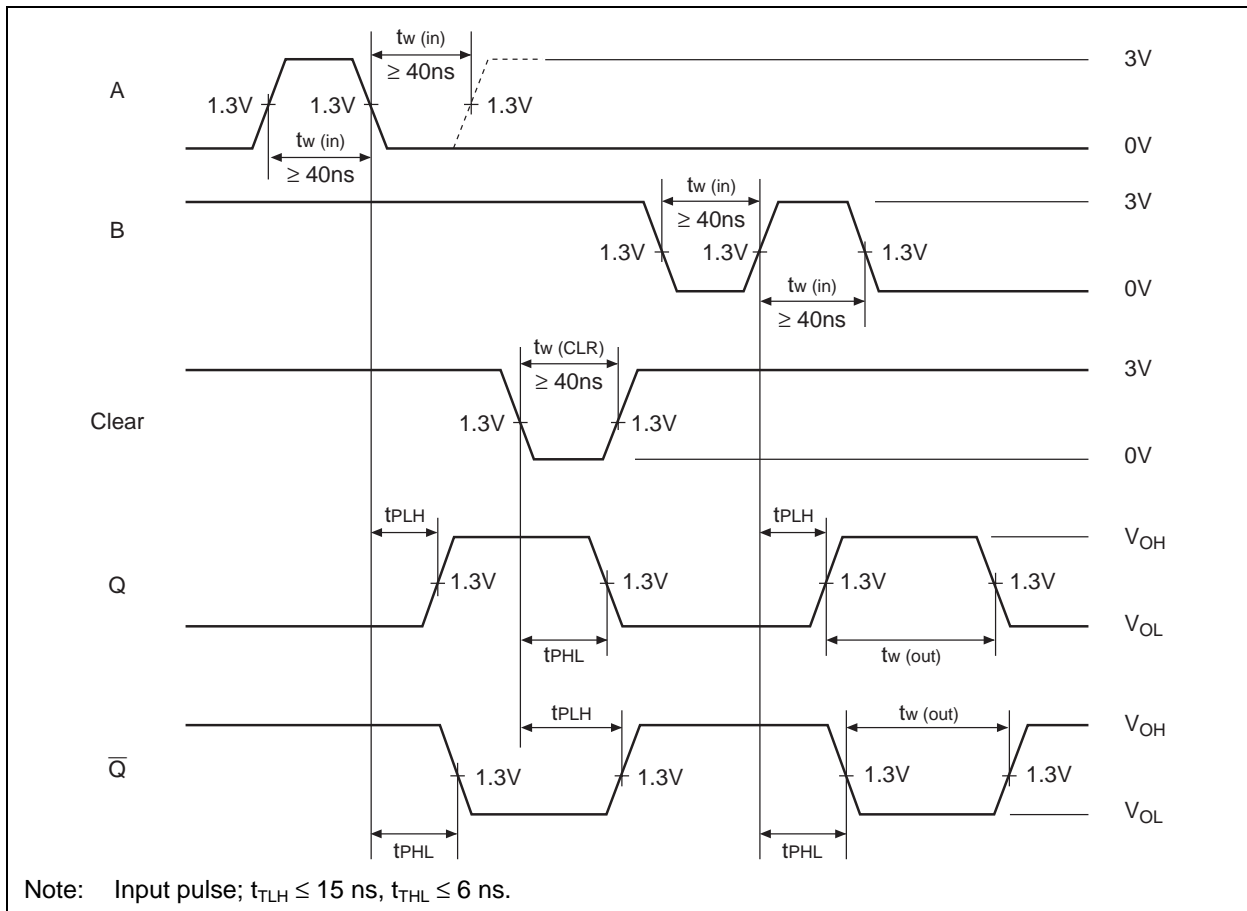

Package Dimensions

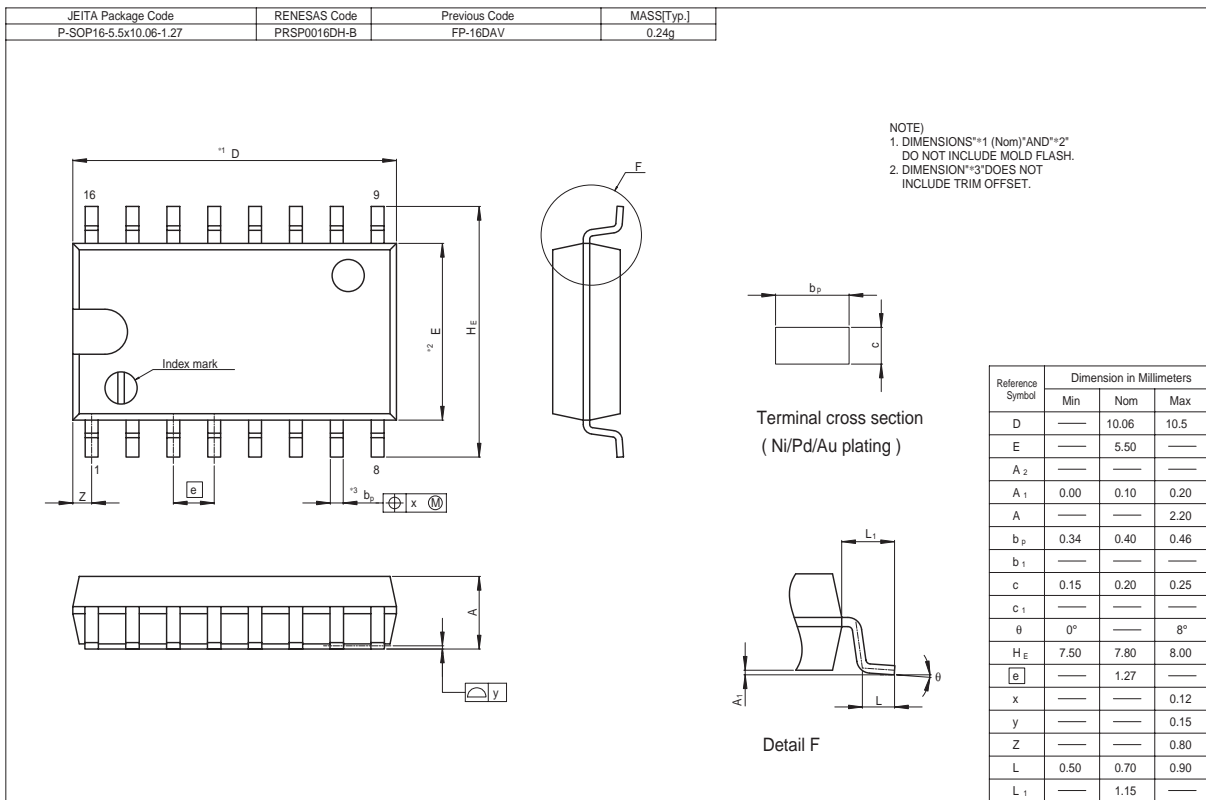
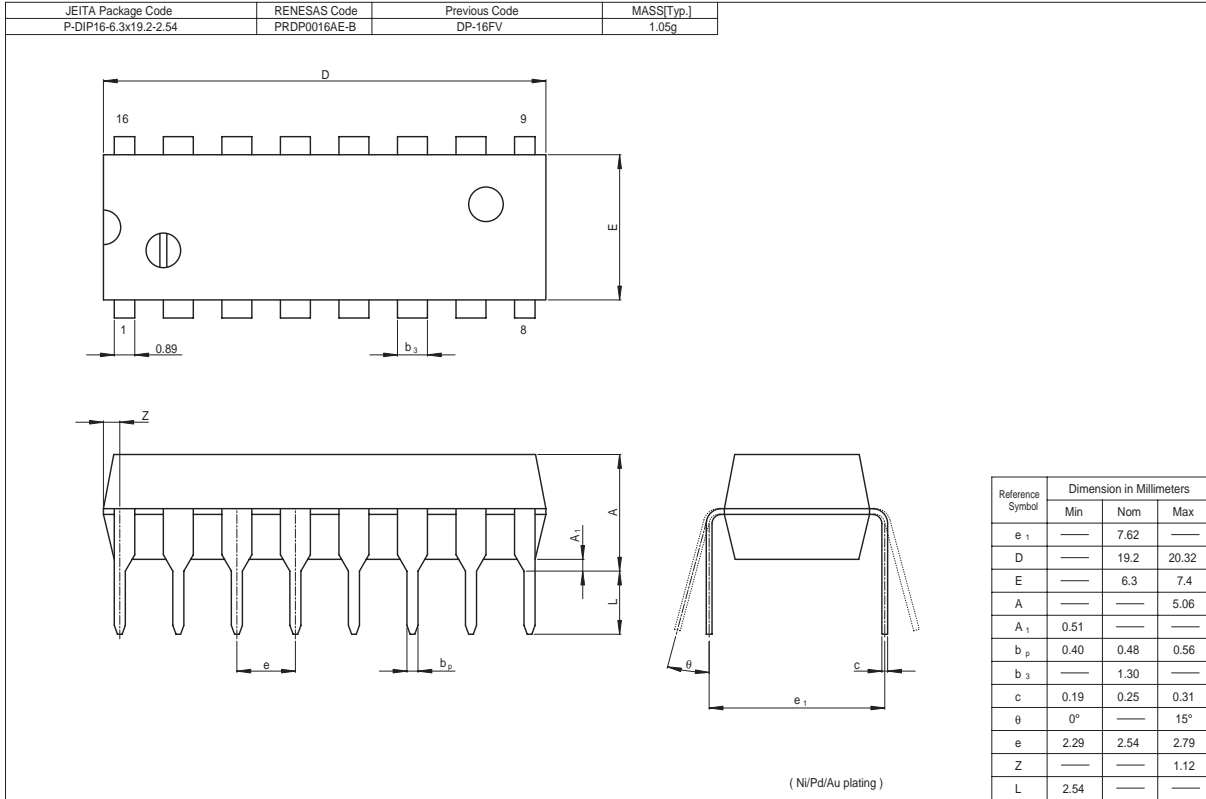

HD74LS123

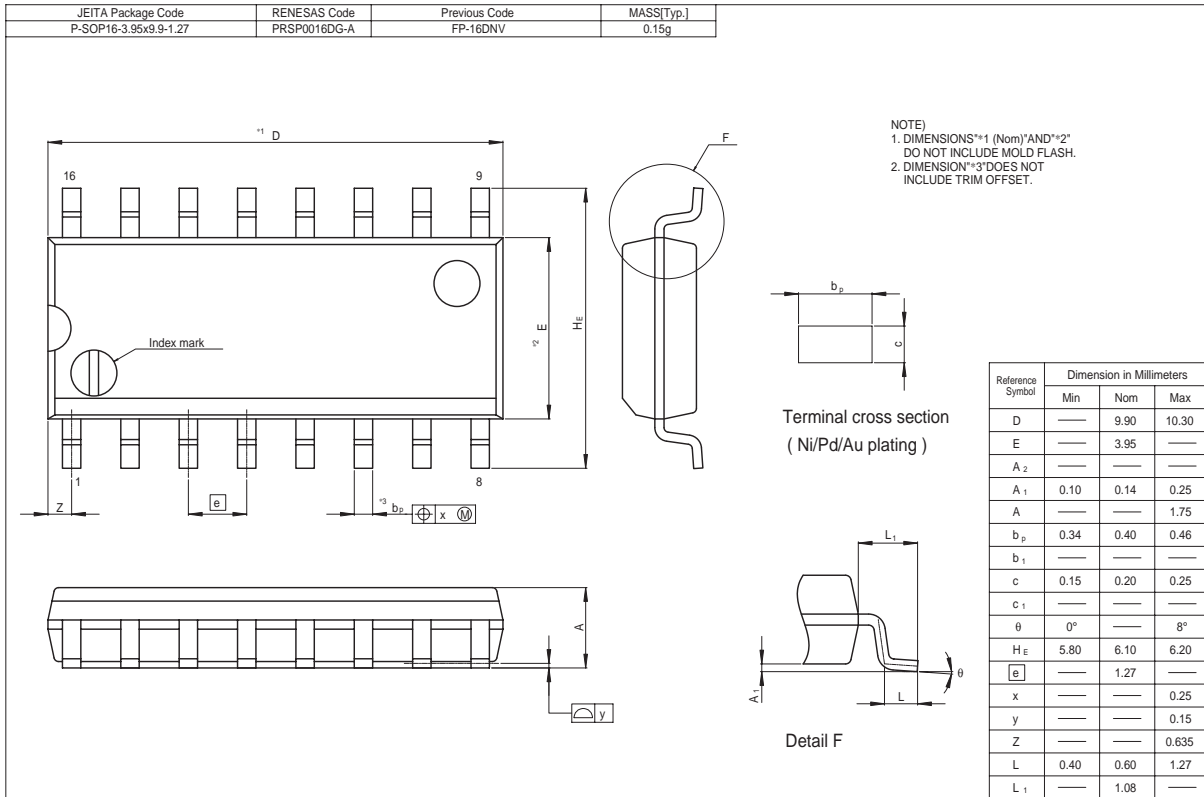

Renesas Technology Corp. Sales Strategic Planning Div. Nippon Bldg., 2-6-2, Ohte-machi, Chiyoda-ku, Tokyo 100-0004, Japan

Keep safety first in your circuit designs!

1. Renesas Technology Corp. puts the maximum effort into making semiconductor products better and more reliable, but there is always the possibility that trouble may occur with them. Trouble with semiconductors may lead to personal injury, fire or property damage. Remember to give due consideration to safety when making your circuit designs, with appropriate measures such as (i) placement of substitutive, auxiliary circuits, (ii) use of nonflammable material or (iii) prevention against any malfunction or mishap.

Notes regarding these materials

1. These materials are intended as a reference to assist our customers in the selection of the Renesas Technology Corp. product best suited to the customer's application; they do not convey any license under any intellectual property rights, or any other rights, belonging to Renesas Technology Corp. or a third party.
 2. Renesas Technology Corp. assumes no responsibility for any damage, or infringement of any third-party's rights, originating in the use of any product data, diagrams, charts, programs, algorithms, or circuit application examples contained in these materials.
 3. All information contained in these materials, including product data, diagrams, charts, programs and algorithms represents information on products at the time of publication of these materials, and are subject to change by Renesas Technology Corp. without notice due to product improvements or other reasons. It is therefore recommended that customers contact Renesas Technology Corp. or an authorized Renesas Technology Corp. product distributor for the latest product information before purchasing a product listed herein. The information described here may contain technical inaccuracies or typographical errors. Renesas Technology Corp. assumes no responsibility for any damage, liability, or other loss rising from these inaccuracies or errors. Please also pay attention to information published by Renesas Technology Corp. by various means, including the Renesas Technology Corp. Semiconductor home page (<http://www.renesas.com>).
 4. When using any or all of the information contained in these materials, including product data, diagrams, charts, programs, and algorithms, please be sure to evaluate all information as a total system before making a final decision on the applicability of the information and products. Renesas Technology Corp. assumes no responsibility for any damage, liability or other loss resulting from the information contained herein.
 5. Renesas Technology Corp. semiconductors are not designed or manufactured for use in a device or system that is used under circumstances in which human life is potentially at stake. Please contact Renesas Technology Corp. or an authorized Renesas Technology Corp. product distributor when considering the use of a product contained herein for any specific purposes, such as apparatus or systems for transportation, vehicular, medical, aerospace, nuclear, or undersea repeater use.
 6. The prior written approval of Renesas Technology Corp. is necessary to reprint or reproduce in whole or in part these materials.
 7. If these products or technologies are subject to the Japanese export control restrictions, they must be exported under a license from the Japanese government and cannot be imported into a country other than the approved destination. Any diversion or reexport contrary to the export control laws and regulations of Japan and/or the country of destination is prohibited.
 8. Please contact Renesas Technology Corp. for further details on these materials or the products contained therein.
-



RENESAS SALES OFFICES

<http://www.renesas.com>

Refer to "<http://www.renesas.com/en/network>" for the latest and detailed information.

Renesas Technology America, Inc.

450 Holger Way, San Jose, CA 95134-1368, U.S.A
Tel: <1> (408) 382-7500, Fax: <1> (408) 382-7501

Renesas Technology Europe Limited

Dukes Meadow, Millboard Road, Bourne End, Buckinghamshire, SL8 5FH, U.K.
Tel: <44> (1628) 585-100, Fax: <44> (1628) 585-900

Renesas Technology Hong Kong Ltd.

7th Floor, North Tower, World Finance Centre, Harbour City, 1 Canton Road, Tsimshatsui, Kowloon, Hong Kong
Tel: <852> 2265-6688, Fax: <852> 2730-6071

Renesas Technology Taiwan Co., Ltd.

10th Floor, No.99, Fushing North Road, Taipei, Taiwan
Tel: <886> (2) 2715-2888, Fax: <886> (2) 2713-2999

Renesas Technology (Shanghai) Co., Ltd.

Unit2607 Ruijing Building, No.205 Maoming Road (S), Shanghai 200020, China
Tel: <86> (21) 6472-1001, Fax: <86> (21) 6415-2952

Renesas Technology Singapore Pte. Ltd.

1 Harbour Front Avenue, #06-10, Keppel Bay Tower, Singapore 098632
Tel: <65> 6213-0200, Fax: <65> 6278-8001