



**ELECTRONICS, INC.**  
 44 FARRAND STREET  
 BLOOMFIELD, NJ 07003  
 (973) 748-5089

## **NTE922, NTE922M, & NTE922SM Integrated Circuit Voltage Comparator**

**Description:**

The NTE922, NTE922M, and NTE922SM are voltage comparators that have input currents nearly a thousand times lower than devices like the NTE910 or NTE910D. They are also designed to operate over a wider range of supply voltages: from standard  $\pm 15V$  op amp supplies down to the single 5V supply used for IC logic. Their output is compatible with RTL, DTL and TTL as well as MOS circuits. Further, they can drive lamps or relays, switching voltages up to 50V at currents as high as 50mA. Both the input and the output of these devices can be isolated from system ground, and the output can drive loads referred to ground, the positive supply or the negative supply. Offset balancing and strobe capability are provided and outputs can be wire OR'ed. Although slower than the NTE910 and NTE910D (200ns response time vs 40ns) the devices are also much less prone to spurious oscillations.

**Features:**

- Operates from single 5V supply
- Input current: 150nA max. over temperature
- Offset current: 20nA max. over temperature
- Differential input voltage range:  $\pm 30V$
- Power consumption: 135mW at  $\pm 15V$
- Available in 3 Different Case Styles:
  - 8-Lead Metal Can: NTE922
  - 8-Lead Mini DIP: NTE922M
  - 8-Lead SOIC (Surface Mount): NTE922SM

**Absolute Maximum Ratings:**

Total Supply Voltage ( $V_{84}$ )	36V
Output to Negative Supply Voltage ( $V_{74}$ )	40V
Ground to Negative Supply Voltage ( $V_{14}$ )	30V
Differential Input Voltage	$\pm 30V$
Input Voltage (Note 1)	$\pm 15V$
Power Dissipation (Note 2)	500mW

Note 1. This rating applied for  $\pm 15V$  supplies. The positive input voltage limit is 30V above the negative supply. The negative input voltage limit is equal to the negative supply voltage or 30V below the positive supply, whichever is less.

Note 2. The maximum junction temperature is 110°C. For operating at elevated temperature, the NTE922 must be derated based on a thermal resistance of 150°C/W, junction-to-ambient, or 45°C/W, junction-to-case. The thermal resistance of the NTE922M and the NTE922SM is 100°C/W, junction-to-ambient.

**Absolute Maximum Ratings (Cont'd):**

Output Short Circuit Duration .....	10sec
Operating Temperature Range .....	0° to +70°C
Storage Temperature Range .....	-65° to +150°C
Lead Temperature (During Soldering, 10 sec) .....	+260°C
Voltage at Strobe Pin .....	V+ -5V

**Electrical Characteristics: (Note 3)**

Parameter	Test Conditions	Min	Typ	Max	Unit
Input Offset Voltage	$T_A = +25^\circ\text{C}$ , $R_S \leq 50\text{k}$ , Note 4	-	2.0	7.5	mV
Input Offset Current	$T_A = +25^\circ\text{C}$ , Note 4	-	6.0	50	nA
Input Bias Current	$T_A = +25^\circ\text{C}$	-	100	250	nA
Voltage Gain	$T_A = +25^\circ\text{C}$	40	200	-	V/mV
Response Time	$T_A = +25^\circ\text{C}$ , Note 5	-	200	-	ns
Saturation Voltage	$V_{IN} \leq -10\text{mV}$ , $I_{OUT} = 50\text{mA}$ , $T_A = +25^\circ\text{C}$	-	0.75	1.5	V
Strobe ON Current	$T_A = +25^\circ\text{C}$	1.5	3.0	-	mA
Output Leakage Current	$V_{IN} \geq 10\text{mV}$ , $V_{OUT} = 35\text{V}$ , $T_A = +25^\circ\text{C}$ , $I_{STROBE} = 3\text{mA}$ , $V_- = V_{GRND} = -5\text{V}$	-	0.2	59	nA
Input Offset Voltage	$R_S \leq 50\text{K}$ , Note 4	-	-	10	mV
Input Offset Current	Note 4	-	-	70	nA
Input Bias Current		-	-	300	nA
Input Voltage Range		-14.5	13.8,-14.7	13.0	V
Saturation Voltage	$V_+ \geq 4.5\text{V}$ , $V_- = 0$ , $V_{IN} \leq -10\text{mV}$ , $I_{SINK} \leq 8\text{mA}$	-	0.23	0.4	V
Positive Supply Current	$T_A = +25^\circ\text{C}$	-	5.1	7.5	mA
Negative Supply Current	$T_A = +25^\circ\text{C}$	-	4.1	5.0	mA

Note 3. These specifications apply for  $V_S = \pm 15\text{V}$  and the Ground pin at GND, and  $0^\circ\text{C} < T_A < +70^\circ\text{C}$ , unless otherwise specified. The offset voltage, offset current and bias current specifications apply for any supply voltage from a single 5V supply up to  $\pm 15\text{V}$  supplies.

Note 4. The offset voltages and offset currents given are the maximum values required to drive the output within a volt of either supply with 1mA load. Thus, these parameters define an error band and take into account the worst-case effects of voltage gain and input impedance.

Note 5. Do not short the strobe pin to ground: it should be current driven at 3 to 5mA.

### Pin Connection Diagram

**NTE922**  
(Top View)

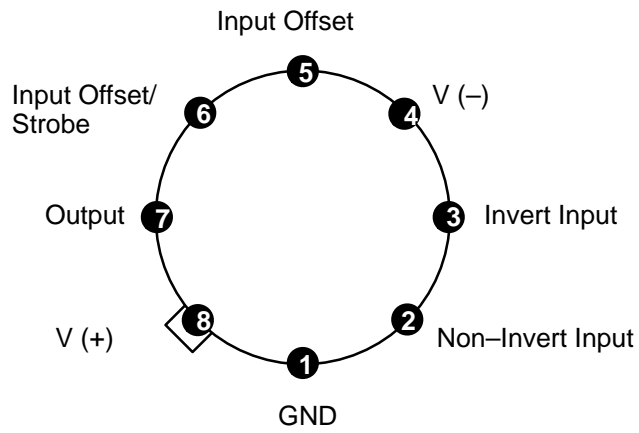

**NTE922M**  
**NTE9122SM**

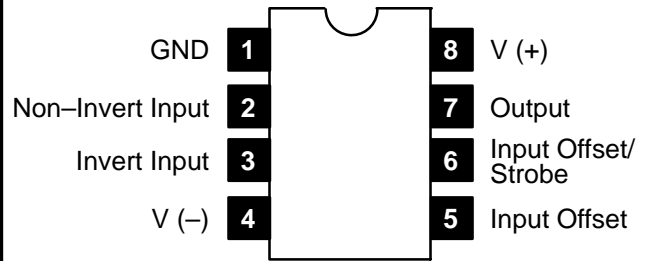

**NTE922**

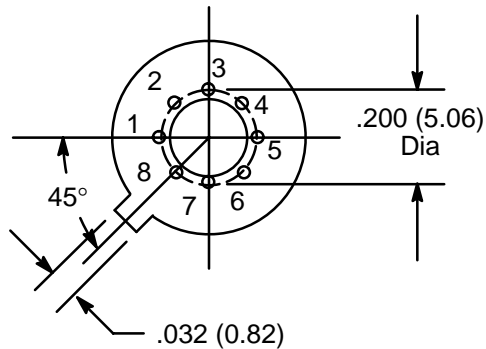
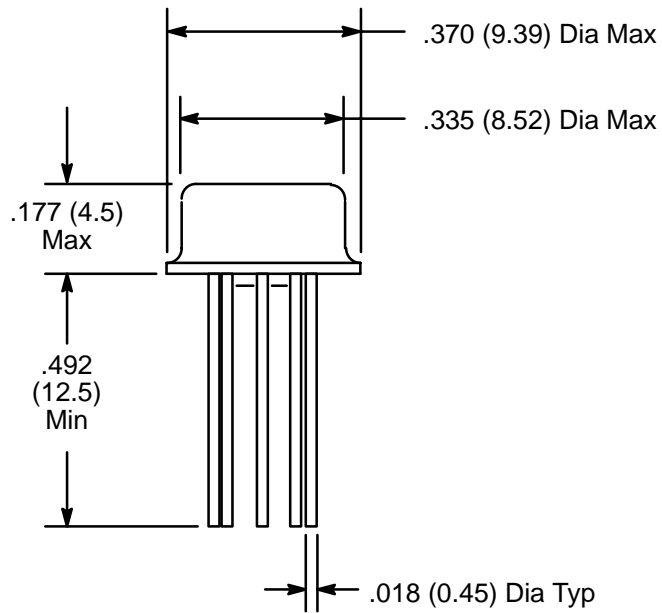

### NTE922M

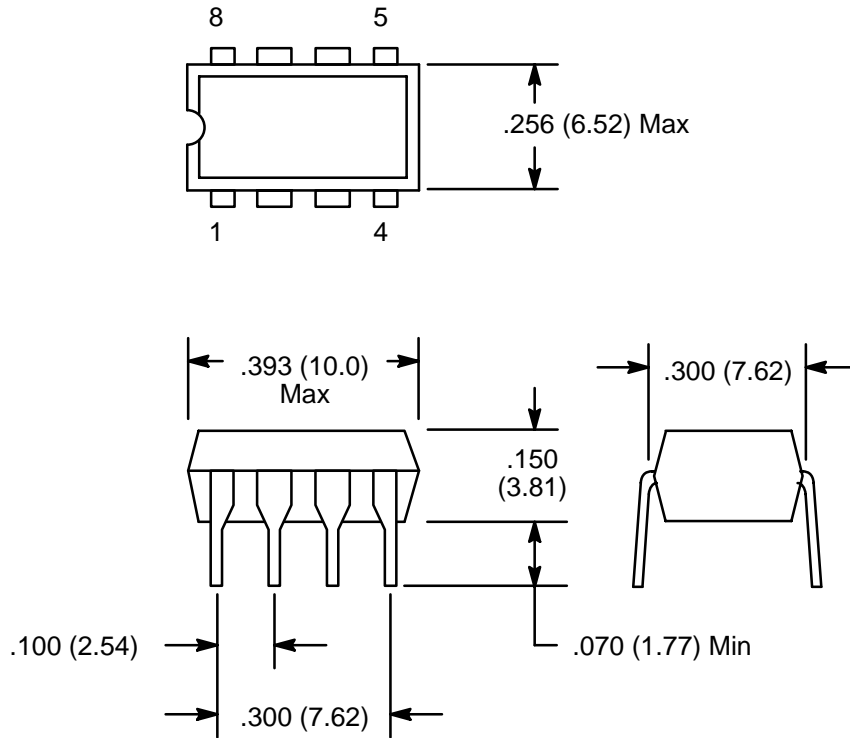

### NTE922SM

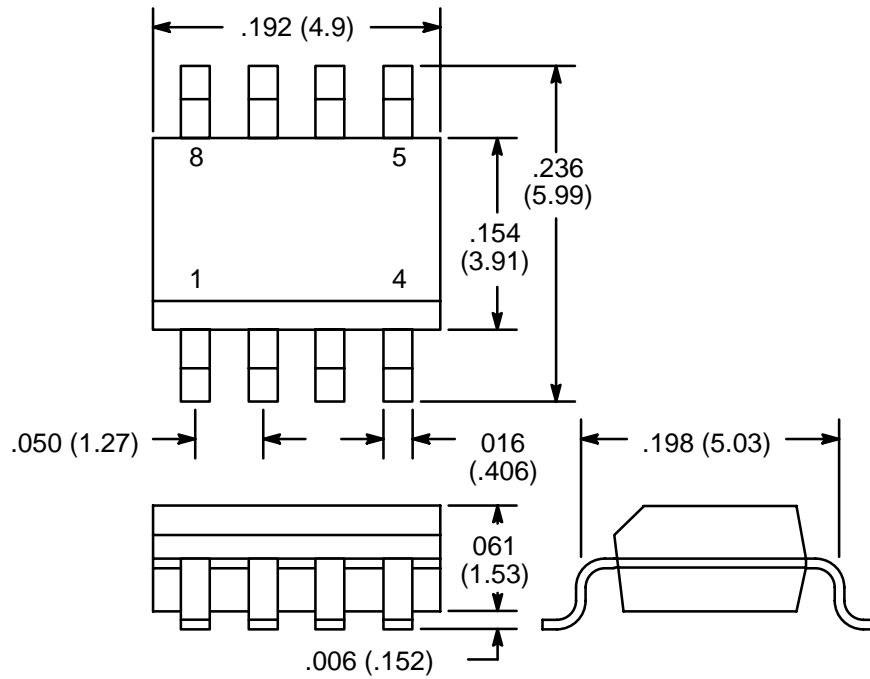

NOTE: Pin1 on Beveled Edge